

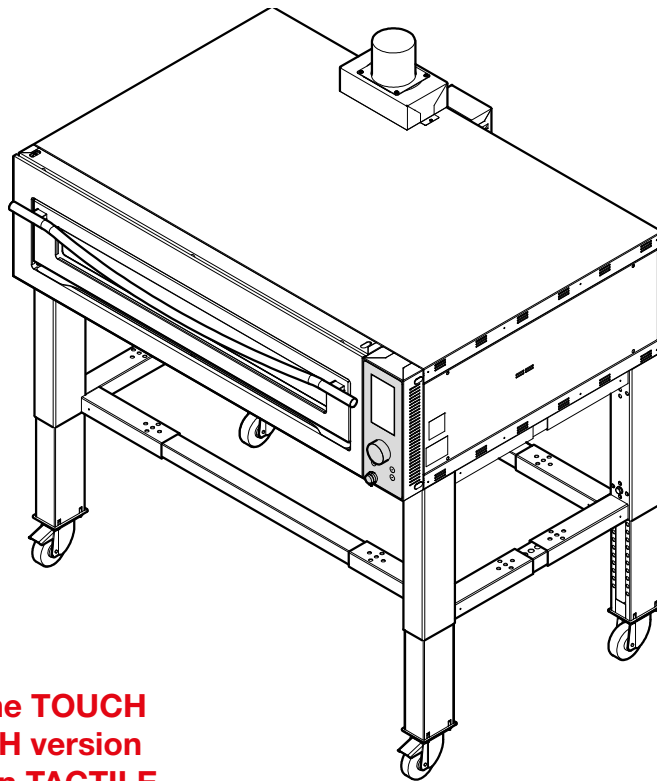

**FORNO PER PIZZA - PIZZA-OVEN - FOUR POUR PIZZA
PIZZA-OFEN - HORNO PARA PIZZA**



IT - Versione TOUCH
EN - TOUCH version
FR - Version TACTILE
DE - TOUCH-Version
ES - Versión TÁCTIL



Mod. SUPERTOP
Mod. SUPERTOP VARIO

- IT** MANUALE D'USO
- EN** USER MANUAL
- FR** MODE D'EMPLOI
- DE** BEDIENUNGSANLEITUNG
- ES** MANUAL DE USO

COSTRUTTORE - MANUFACTURER - PRODUCTEUR
- HERSTELLER - FABRICANTE



OEM ALI Group S.r.l. a Socio Unico
Viale Lombardia, 33
46012 BOZZOLO (MN) Italia
Tel.: +39 0376 - 910511 - Fax: +39 0376 - 920754

SEDI o AGENTI - OFFICES OR AGENTS - SIÈGES OU AGENTS
NIEDERLASSUNGEN oder VERTRETER - SEDES y AGENTES



.....

.....

Tel. : -

Fax. : -



.....

.....

Tel. : -

Fax. : -

Modello.

Model - Modèle - Modell - Modelo

Numero di matricola.

Serial number - Numéro d' immatriculation - Kenn-Nummer - Número de matrícula

Data di consegna.

Delivery date - Date di livraison - Lieferdatum - Fecha de entrega

DICHIARAZIONE CE DI CONFORMITA'
DECLARATION OF CONFORMITY - DECLARATION CE DE CONFORMITE
CE-KONFORMITÄTSEKTLÄRUNG - DECLARACIÓN CE DE CONFORMIDAD'



OEM ALI Group S.r.l. a Socio Unico

Viale Lombardia, 33

46012 BOZZOLO (MN) Italia

Tel.: +39 0376 - 910511 - Fax: +39 0376 - 920754

Dichiara che il modello - *It is hereby declared that model*
Déclare que le modèle - *erklärt, daß die Maschine Modell*
Declara que el modelo

SUPERTOP 435 - 635S - 635L - 935
SUPERTOP VARIO 440 - 640S - 640L - 940

IT è conforme alle disposizioni legislative che traspongono le direttive e successivi emendamenti:
EN *complies with the law provisions that transpose the directives and relevant amendments:*
FR est conforme aux dispositions législatives qui transposent les directives et amendements successifs:
DE *den gesetzlichen Richtlinienbestimmungen und nachfolgenden Änderungen:*
ES es conforme a las disposiciones legislativas que transponen las directivas y sucesivas enmiendas:

2014/35 UE - 2014/30 UE - 2006/42 CE - 2012/19 CE

IT e inoltre dichiara che sono state applicate le seguenti norme armonizzate
EN *it is also hereby declared that the following harmonized provisions have been applied*
FR et en plus elle déclare que les normes suivantes ont été appliquées
DE *sowie folgenden harmonisierten Normen:*
ES y declara además que han sido aplicadas las siguientes normas armonizadas

EN 55014-1:2006; EN 55014-2:1997+A1:2001 + A2:2008; EN 61000-3-2:2006;
EN 61000-3-3:1995+A1:2001+A1:2001+A2/ISI:2005; EN 61000-3-11:2000
EN 61000-3-12:2005; EN 62233:2008
EN 60335-2-36:2000 + A1:2004 + A2:2008 (EN 60335-1:2002+A1:2004+A11:2004+A12:2006+A2:2006)

INDICE GENERALE

GENERAL INDEX - INDEX GENERAL

ALLGEMEINES INHALTSVERZEICHNIS - ÍNDICE GENERAL -

Italiano Pag.**IT - 1**
(Istruzioni originali)

English Pag.**EN - 1**
(Translation of original instructions)

Français Pag.**FR - 1**
(Traduction des instructions d'origine)

Deutsch Seite.**DE - 1**
(Übersetzung der Originalanleitung)

Español Pag.**ES - 1**
(Traducción de las instrucciones originales)

ENGLISH

<p>CHAPTER 1</p> <p><i>Chapter for the technician and operator</i></p> <p>1.1 GENERAL WARNINGS.....3</p> <p>1.2 REFERENCE NORMATIVE.....5</p> <p>1.3 DESCRIPTION OF THE SYMBOLS.....5</p> <p>1.4 MACHINE COMPOSITION.....5</p> <p>1.5 PREARRANGEMENTS AT PURCHASER'S CHARGE.....6</p> <p>1.6 EMERGENCY OPERATIONS IN CASE OF FIRE.....6</p> <p>1.7 EXPLOSION RISK.....6</p> <p>1.8 ACOUSTIC PRESSURE LEVEL.....6</p> <p>1.9 FILE IN DIGITAL FORMAT.....6</p>	<p>5.5 PROGRAMMING BAKING PARAMETERS.....27</p> <p>5.6 CHAMBER LIGHTING.....28</p> <p>5.7 USER MENU.....29</p> <p>5.8 AUTO POWER-ON TIMER.....30</p> <p>5.9 CALENDAR.....31</p> <p>5.10 COOKING ASSISTANCE FUNCTION.....31</p> <p>5.11 DISPLAYING RECIPES AND MANUAL.....32</p> <p>5.12 RECIPE ENTRY MODE.....33</p> <p>5.13 OVEN PREPARATION.....36</p> <p>5.14 PIZZA BAKING.....37</p> <p>5.15 ALARMS.....38</p> <p>5.16 SWITCH-OFF.....41</p> <p>5.17 MALFUNCTIONING, CAUSE AND CURE.....41</p>
<p>CHAPTER 2</p> <p><i>Chapter for the technician</i></p> <p>2.1 TECHNICAL FEATURES.....9</p> <p>2.2 TRANSPORT.....12</p> <p>2.3 RECEPTION OF THE MACHINE.....13</p> <p>2.4 UNPACKING.....13</p> <p>2.5 IDENTIFICATION OF THE COMPONENTS.....14</p> <p>2.6 IDENTIFICATION OF THE MACHINE.....14</p>	<p>CHAPTER 6</p> <p><i>Chapter for the technician and operator</i></p> <p>6.1 ROUTINE AND PLANNED MAINTENANCE.....42</p> <p>6.1.a In general.....42</p> <p>6.1.b Ordinary maintenance.....42</p> <p>6.1.b.a Self-cleaning cycle.....42</p> <p>6.1.b.b Outer cleaning.....43</p> <p>6.1.b.c Refractory surface cleaning.....43</p> <p>6.1.c Scheduled service interventions.....43</p> <p>6.1.d Service intervention according to the specific requirements.....43</p> <p>6.1.d.a Lamp replacement.....43</p> <p>6.1.d.b How to clean the cooling fan of the switchboard.....44</p> <p>6.2 RESETTING THE SAFETY THERMOSTAT.....45</p> <p>6.3 - REACTIVATION OF THE STEAMER SAFETY THERMOSTAT.....46</p>
<p>CHAPTER 3</p> <p><i>Chapter for the technician</i></p> <p>3.1 UNIT LIFTING.....15</p> <p>3.2 VERTICAL HANDLING OF THE OVEN.....15</p> <p>3.3 ASSEMBLING OF THE COMPONENTS.....15</p> <p>3.4 ELECTRIC CONNECTION.....17</p> <p>3.5 OVEN POSITIONING.....18</p>	<p>CHAPTER 7</p> <p><i>Chapter for the technician</i></p> <p>7.1 MACHINE DISASSEMBLING.....47</p> <p>7.2 DEMOLISHING THE MACHINE.....47</p> <p>7.3 DISPOSING OF HARMFUL SUBSTANCES.....47</p> <p>“SUPER TOP” OVEN DIAGRAM - 208/240 Volt 3Ph + PE.....48</p> <p>“SUPER TOP” OVEN DIAGRAM - 380/416 Volt 3Ph + N + PE.....50</p> <p>“VARIO” OVEN STEAM COOKER DIAGRAM.....54</p>
<p>CHAPTER 4</p> <p><i>Chapter for the technician and operator</i></p> <p>4.1 INTENDED USE.....20</p> <p>4.2 IMPROPER USE.....20</p> <p>4.3 SAFETY PLATES.....20</p> <p>4.4 SAFETY DEVICES.....21</p> <p>4.5 USER'S AREAS.....21</p> <p>4.6 RESIDUAL DANGER AREAS.....21</p> <p>4.7 DANGER ZONES.....21</p>	<p>CHAPTER 5</p> <p><i>Chapter for the technician and operator</i></p> <p>5.1 DIGITAL OVEN CONTROL PANEL.....24</p> <p>5.2 USER INTERFACE.....25</p> <p>5.3 MAIN SCREEN.....26</p> <p>5.4 SELECTING PROGRAMS OR CHANGING PARAMETERS.....27</p>

INTENTIONALLY WHITE PAGE

Chapter 1

1.1 - GENERAL WARNINGS

- Before setting the machine at work the operator should have carefully read these instructions and have acquired a deep knowledge of the technical specifications and control devices.
- **To the operator is suggested to attend a training course on the use of the machine.**
- Before installing the machine make sure that the used area is compatible with the dimensions and the weight of the machine.
- For the installation or removal of any machine part, the used lifting and handling devices should be suitable to the weight and geometrical characteristics of the part to be lifted or handled.
- The control panel is not part of the area of the machine in contact with food; take appropriate precautions to prevent the operator from making cross-contact between commands and food.
- Only skilled and authorized personnel is allowed to start adjust or repair the machine. This handbook should be always consulted before to do any work on the machine.
- Mechanical parts and electrical components inside the machine are protected by totally enclosed panels fastened with screws.
- Before cleaning and/or maintaining the machine and before removing any type of protection, **make sure that the general switch is on "OFF" position (O)**, in order to turn off the power while the operator is working.
- The power supply system of the purchaser should be provided with an automatic release device above the machine main switch and with a suitable earthing system complying with the accident prevention regulations.
- In case of repairs to be done on the main switch or in the main switch area, turn off the power of the electrical line.
- Any inspection and maintenance works requiring the removal of the safety protections are made under the responsibility of the user. **Therefore it is recommended that the above mentioned works are done by authorized and skilled personnel only.**
- Make sure that all safety devices (barriers, protections, carter, micro-switches, etc.) have not been tampered and are perfectly working. On the contrary, they should be repaired.
- **Do not remove the safety devices.**
- In order to avoid personal risks, only suitable tools should be used, in accordance with the local safety regulations.
- Do not tamper the electric and pneumatic plant or any other mechanism for any reason.
- Do not leave the machine unattended while it is working.
- Wear safety clothing only, approved by the law in force.
- Be careful! the floor near the oven can be slippery. Equip yourself with appropriate non-slip shoes.
- In case of works to be done in a position that cannot be reached from the ground, use safe ladders or lifting devices only, in conformity with the local safety regulations.

- In case of repairs to be done near or under the machine, make sure that:
 - there are no machine members that can start working and/or instable parts placed on the machine or near the machine.
 - Do not use your hands instead of suitable tools to work on the machine.
 - Do not use your hands or other tools to stop any moving parts.
 - Do not use matches, lighters or flames near the machine.
 - **YOUR BEST ATTENTION SHOULD BE PAID TO THE WARNING PLATES LOCATED ON THE MACHINE BEFORE DOING ANY WORK ON THE MACHINE OR NEAR THE MACHINE.**
 - The user is obliged to keep all the warning plates in legible conditions and, if required, to change their position in order to make them fully visible to the operator.
 - Moreover the user is obliged to replace any warning plate that, for any reason, has been damaged or is not clearly legible. New warning plates can be obtained through our Technical Service Centre.
 - **Stop the machine before doing any repair work.**
 - In case of malfunction of the machine or damages to its components, get in touch with the maintenance engineer and do not try to repair the machine.
 - **It is absolutely prohibited to use the machine for other purposes different from those expressly indicated and documented.**
- The machine should be used always when and how provided by the good technique, in compliance with the EEC machine directive and in compliance with the regulations concerning health and safety of the workers, as indicated by the local regulations or according to the EEC directive 89/391.
- Children must not play with the device.
 - The cleaning and maintenance, intended to be carried out by the user, must not be carried out by children.
 - **The manufacturer declines all responsibility for any injury or damage to persons or things arising from inobservance of the safety regulations and the instructions contained in this manual.**
 - **THESE SAFETY REGULATIONS INTEGRATE OR COMPLEMENT THE LOCAL SAFETY REGULATIONS.**
 - **DO NOT make hurried or inaccurate repairs that may compromise the good running of the machine and the safety of the operator.**
 - **IN CASE OF DOUBT ALWAYS ASK FOR THE PRESENCE OF SKILLED PERSONNEL.**
 - **FOR ANY ELECTRIC/ELECTRONIC OR MECHANIC TAMPERING OF THE MACHINE BY THE USER OR IN CASE OF A NEGLIGENT USE OF THE MACHINE, THE MANUFACTURER IS RELIEVED FROM ANY RESPONSIBILITY AND THE USER WILL BE THE ONLY ONE RESPONSIBLE AGAINST THE COMPETENT AUTHORITIES FOR THE ACCIDENT PREVENTION.**
- 1.2 - REFERENCE NORMATIVE

- The machine and its safety components have been manufactured in compliance with the directives indicated in the declaration of conformity.

1.3 - DESCRIPTION OF THE SYMBOLS

Many accidents are caused by a poor knowledge of and by a non compliance with the safety regulations to put into practice during the functioning and maintenance works to be done on the machine.

In order to avoid any accidents, read understand and follow all the warnings and cautions contained in this booklet and those written on the plates located on the machine.

To identify the safety messages included in this booklet, following symbols have been used:



DANGER

This symbol is used in the safety messages contained in the booklet in case of potential danger situations or possibility to cause serious injuries or dead.



ATTENTION

This symbol is used in the safety messages of the booklet for any danger situation that, if disregarded, may cause small or moderate injuries or damages.

The message can be used also in case of danger situations that may cause damages to the machine.



IMPORTANT

This symbol is used in case of precautionary measures to be taken in order to avoid any operation that may reduce the life of the machine or for important communication to the operator.



DANGER

For clarity reasons, some illustrations of this booklet show the machine without safety guards. **DO NOT USE THE MACHINE WITHOUT SAFETY GUARDS.**

This symbol indicates that it is mandatory to read the instructions for use and maintenance before using the device.

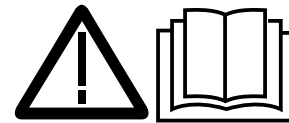

This symbol is placed on the parts of the machine that reach a high temperature. It indicates the danger of burns.



This symbol is placed next to a special terminal and it indicates that the machine must be connected to an equipotential network.



1.4 - MACHINE COMPOSITION

Manufacturer's machines are the results of a considerable experience.

- Ovens can be fitted with one single, two or three chambers, digitally operated.
- If requested by a customer, a smoke extracting kit can be positioned on the rear or upper side of the oven and can be controlled by operating the control board of the oven.
- The oven/s is/are placed on a bearing base equipped with wheels.

1.5 - PREARRANGEMENTS AT PURCHASER'S CHARGE

- a) Prerearrangement of the installation place.**
- The purchaser shall prerearrange a supporting surface for the machine as indicated in the chapter "Installation".
- b) Electric prerearrangement.**
- The power system should comply with the local regulations and provided with an efficient earthing.
 - Place an omnipolar sectioning device on the power feed line, above the machine.
 - **The size of the electric power cables should comply with the maximum current required by the machine, so that the total voltage drop at full charge will be less than 2%.**
- c) Flue prerearrangement**
- It is necessary to prerearrange a vapour flue, whose features shall be in compliance with the rules being in force in the Country the oven shall be installed in.
- d) Neutral wire**
- The machine is equipped with neutral wire, therefore, a special terminal being identified according to the relevant directions has been prerearranged.
- e) Water supply (only for version with steamer)**
- The water supply and drainage system must be in conformity with the provisions laid down in the national regulations in force.

Supply

- Place a partialization tap upstream of the oven between the oven and the power plant.
Arrange a water supply line near the area where the oven will be installed.

Drainage

- Arrange a water drain-pipe at the back of the oven.

1.6 - EMERGENCY OPERATIONS IN CASE OF FIRE

- a) In case of fire turn off the power by disconnecting the main power switch.
- b) Put out the fire by means of suitable fire extinguishers.



Do not attempt to put out the fire by using water.

1.7 - EXPLOSION RISK

- The machine is not suitable to be used in a place with explosion risk.

1.8 - ACOUSTIC PRESSURE LEVEL

With SUPERTOP / SUPERTOP VARIO ovens, an A acoustic continuous equivalent weighted pressure level(dB) under the maximum allowed 70dB level is kept.

1.9 - DIGITAL FORMAT FILE

This manual can be downloaded in pdf format by linking to the site:

www.oemali.com

Chapter 2

OVERALL DIMENSIONS

SUPERTOP

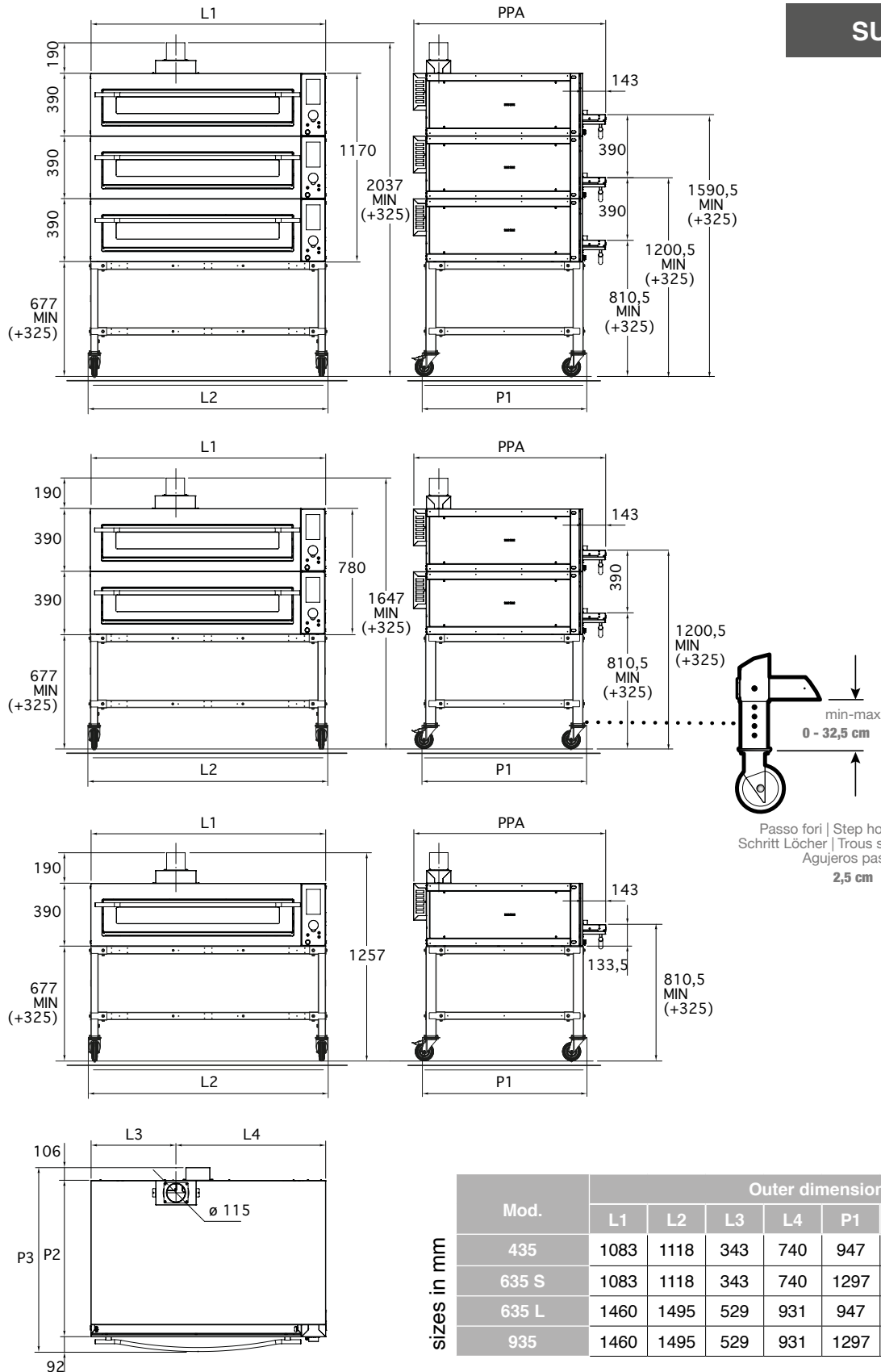

OVERALL DIMENSIONS

SUPERTOP VARIO

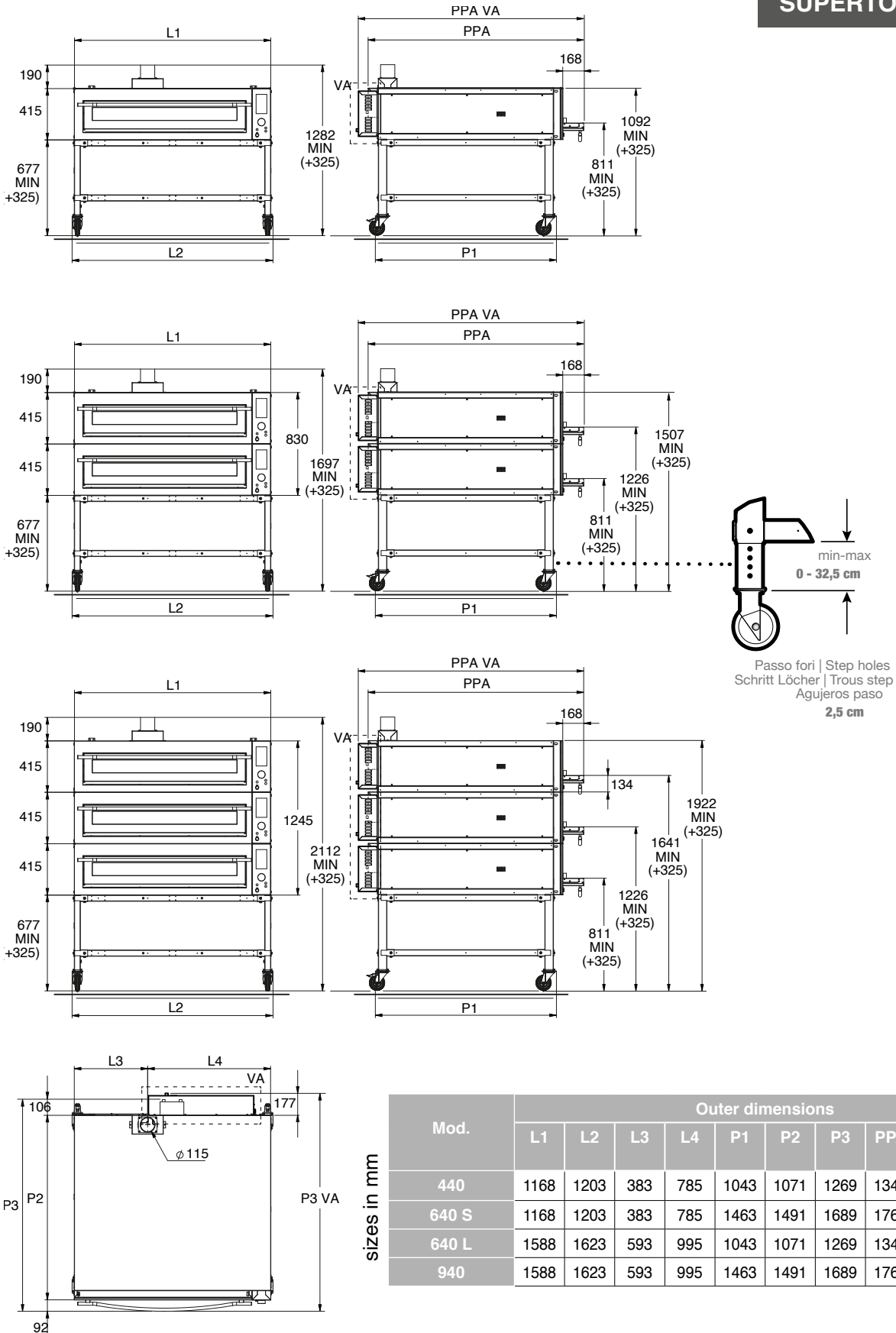

Mod.	Outer dimensions									
	L1	L2	L3	L4	P1	P2	P3	PPA	P3 (VA)	PPA (VA)
440	1168	1203	383	785	1043	1071	1269	1345	1340	1416
640 S	1168	1203	383	785	1463	1491	1689	1765	1760	1836
640 L	1588	1623	593	995	1043	1071	1269	1345	1340	1416
940	1588	1623	593	995	1463	1491	1689	1765	1760	1836

2.1 - TECHNICAL FEATURES

Model	435			635S		
Electric connection	208/240V 1Ph+PE 36,5A	208/240V 3Ph+PE 21,5A	380/416V 3Ph+N+PE 12,5A	208/240V 1Ph+PE 45,7A	208/240V 3Ph+PE 26,5A	380/416V 3Ph+N+PE 15,5A
Power	8,4 kW			10,5 kW		
cable section	3 x 10 mm ²	4 x 6 mm ²	5 x 2,5 mm ²	3 x 16 mm ²	4 x 6 mm ²	5 x 4 mm ²
Net weight	160 kg			200 kg		
relative humidity	10 ÷ 80 %					

Model	635L			935		
Electric connection	208/240V 1Ph+PE 66A	208/240V 3Ph+PE 38A	380/416V 3Ph+N+PE 22A	208/240V 1Ph+PE 82,5A	208/240V 3Ph+PE 47,5A	380/416V 3Ph+N+PE 27,5A
Power	15,1 kW			18,9 kW		
cable section	3 x 25 mm ²	4 x 10 mm ²	5 x 6 mm ²	3 x 35 mm ²	4 x 16 mm ²	5 x 6 mm ²
Net weight	200 kg			250 kg		
relative humidity	10 ÷ 80 %					

Model without steamer

Model	440			640S		
Electric connection	208/240V 1Ph+PE 52,2A	208/240V 3Ph+PE 30,2A	380/416V 3Ph+N+PE 17,4A	208/240V 1Ph+PE 78,3A	208/240V 3Ph+PE 45,2A	380/416V 3Ph+N+PE 26,1A
Power	12Kw			18Kw		
cable section	3x10mm ²	4x6mm ²	5x4mm ²	3x16mm ²	4x10mm ²	5x6mm ²
Net weight	160 kg			200Kg		
relative humidity	10 ÷ 80 %					

Model	640L			940		
Electric connection	208/240V 1Ph+PE 78,3A	208/240V 3Ph+PE 45,2A	380/416V 3Ph+N+PE 26,1A	208/240V 1Ph+PE 91,3A	208/240V 3Ph+PE 52,7A	380/416V 3Ph+N+PE 30,5A
Power	18Kw			21Kw		
cable section	3x16mm ²	4x10mm ²	5x6mm ²	3x25mm ²	4x10mm ²	5x6mm ²
Net weight	200Kg			250Kg		
relative humidity	10 ÷ 80 %					

Model with steamer

Model	440			640S		
Electric connection	208/240V 1Ph+PE 62,6A	208/240V 3Ph+PE 36,2A	380/416V 3Ph+N+PE 20,3A	208/240V 1Ph+PE 88,7A	208/240V 3Ph+PE 51,2A	380/416V 3Ph+N+PE 29,6A
Power	14,4Kw			20,4Kw		
cable section	3x16mm ²	4x10mm ²	5x4mm ²	3x25mm ²	4x10mm ²	5x6mm ²
Net weight	200Kg			240Kg		
relative humidity	10 ÷ 80 %					

Model	640L			940		
Electric connection	208/240V 1Ph+PE 88,7A	208/240V 3Ph+PE 51,2A	380/416V 3Ph+N+PE 29,6A	208/240V 1Ph+PE 101,8A	208/240V 3Ph+PE 58,8A	380/416V 3Ph+N+PE 34,0A
Power	20,4Kw			23,4Kw		
cable section	3x25mm ²	4x10mm ²	5x6mm ²	3x25mm ²	4x16mm ²	5x10mm ²
Net weight	240Kg			290Kg		
relative humidity	10 ÷ 80 %					

Dimension	Position		kW of the electric resistance	total kW
435	heaven	mouth resistor	1,9	8,4
		centre resistor	1,6	
		bottom resistor	1,6	
	background	mouth resistor	1,1	
		centre resistor	1,1	
		bottom resistor	1,1	
635L	heaven	mouth resistor	3,5	15,1
		centre resistor	2,8	
		bottom resistor	2,8	
	background	mouth resistor	2	
		centre resistor	2	
		bottom resistor	2	
635S	heaven	mouth resistor	1,9	10,5
		centre resistor	1,9	
		bottom resistor	1,9	
	background	mouth resistor	1,6	
		centre resistor	1,6	
		bottom resistor	1,6	
935	heaven	mouth resistor	3,5	18,9
		centre resistor	3,5	
		bottom resistor	3,5	
	background	mouth resistor	2,8	
		centre resistor	2,8	
		bottom resistor	2,8	

Dimension	Position		kW of the electric resistance	total kW
440	heaven	mouth resistor	2,2	12
		centre resistor	1,9	
		bottom resistor	1,9	
	background	mouth resistor	2,2	
		centre resistor	1,9	
		bottom resistor	1,9	
640L	heaven	mouth resistor	1,65	18
		mouth resistor	1,47	
		centre resistor	1,47	
		centre resistor	1,47	
		bottom resistor	1,47	
		bottom resistor	1,47	
	background	mouth resistor	1,65	
		mouth resistor	1,47	
		centre resistor	1,47	
		centre resistor	1,47	
		bottom resistor	1,47	
		bottom resistor	1,47	
640S	heaven	mouth resistor	3,5	18
		centre resistor	2,9	
		bottom resistor	2,9	
	background	mouth resistor	2,9	
		centre resistor	2,9	
		bottom resistor	2,9	
940	heaven	mouth resistor	2,35	20,8
		mouth resistor	1,15	
		centre resistor	1,15	
		centre resistor	1,15	
		centre resistor	1,15	
		bottom resistor	1,15	
		bottom resistor	1,15	
	background	mouth resistor	2,35	
		mouth resistor	1,15	
		centre resistor	1,15	
		centre resistor	1,15	
		centre resistor	1,15	
		bottom resistor	1,15	
		bottom resistor	1,15	

2.2 - TRANSPORT

2.2.a - Shipment (Fig. 1)

The machine is positioned on a wooden pallet, fastened with screws, inside a strapped carton.

The machine can be delivered with one of the following means of transport:

- a) Land transport (lorry)
- b) Air transport
- c) Sea transport
- d) Railway transport

The way of transport will be agreed in course of contract between supplier and purchaser.



IMPORTANT

The packing containing the machine should be kept away from the weather. Do not put other boxes or materials on it.

2.2.b - Lifting of the packing (Fig. 2)

The box should be handled with the most care. To lift and to position the box use suitable lifting systems, according to the weight of the machine.

The box should be lifted by using a crane or a hoist with appropriate belts or by means of a lift track, by inserting the forks in the appropriate joints.



DANGER



Any handling and lifting operation should be done by skilled personnel, authorized to use appropriate equipments.

The manufacturer declines all responsibility for any damage to persons or things caused by inobservance of the current safety regulations regarding lifting and moving of materials inside or outside the factory.

2.2.c - Storage



IMPORTANT

The box containing the machine should be stored away from weather. Do not put other boxes or materials on it.

FIG. 1

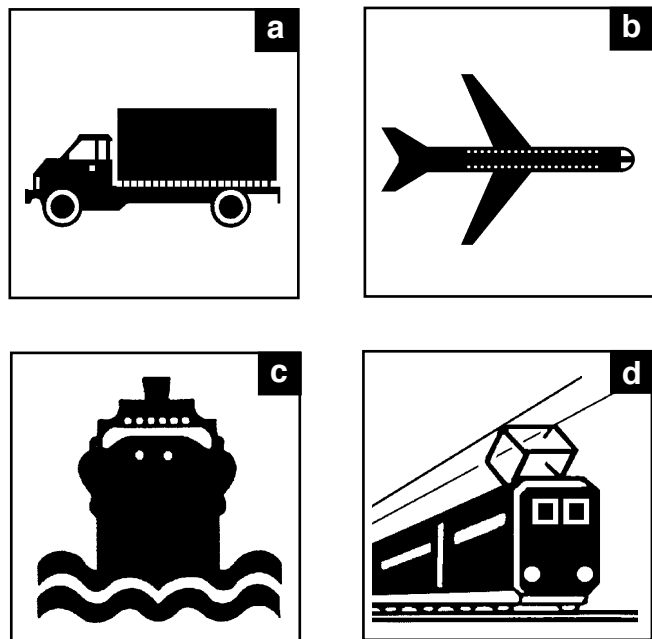
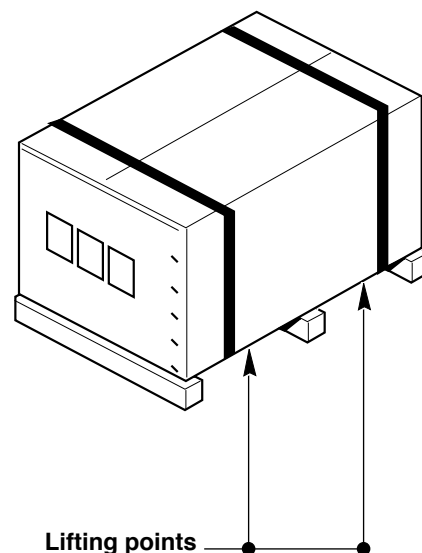

FIG. 2



2.3 - RECEPTION OF THE MACHINE

Upon reception of the machine make sure that the packing is complete and not damaged. Should the packing be complete, remove it as specify at point 2.4 (aside from different manufacturer's instructions).

Check if the instruction booklet is inside the packing as well as the components specified in the transport documentation.

In case any damage or defect is found:

- a- Inform immediately the transport company and your agent, both by phone and by registered letter with return receipt;
- b- Manufacturer shall also be informed.



IMPORTANT

The oven consists of three distinct parts: support, cover or hood. Each part is packed, separately; on installation, the components are assembled.

FIG. 3

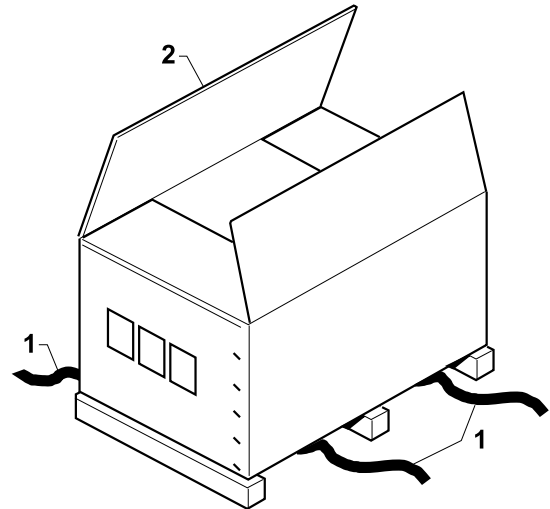

2.4 - UNPACKING (Fig. 3)

To remove the packing from the machine proceed as follows:

- Cut the straps (1) that tie up the carton.
- Open the carton (2), by removing the metallic clips.
- Remove the cardboard packaging (2).
- Check if everything is complete.
- Open the oven door (3), remove the refractory material fastening carton and the loose components, as well.
- Check if the delivery is complying with the PACKING LIST.



DANGER

The packing elements (plastic bags, carton, nails, etc...) shall be kept away from the reach of the children, since they are potential danger sources, so, they shall be gathered and sent to special centres to correctly be recycled.



IMPORTANT

Any damage or defect or non conformity with the packing list should be immediately reported and, in any case, it should be notified within 8 days from the date of reception of the machine. On the contrary the goods are to be considered as accepted.

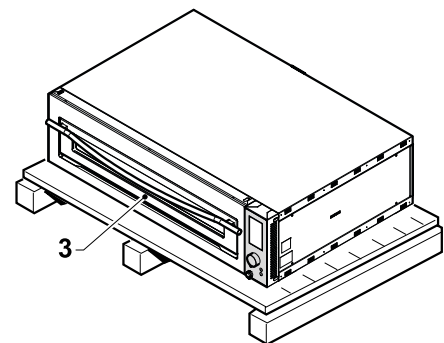

2.5 - IDENTIFICATION OF THE COMPONENTS (Fig. 4)

1. Data plate
2. Oven
3. Chimney
4. Support (by request)
5. Wheels
6. Control board
7. Steamer (if present)

2.6 - IDENTIFICATION OF THE MACHINE (Fig. 4)

The serial number and identification data of the machine are punched on a plate (1) fastened to the machine base.



IMPORTANT

The machine serial number should be always mentioned in your request of technical assistance or in your spare part orders.

FIG. 4

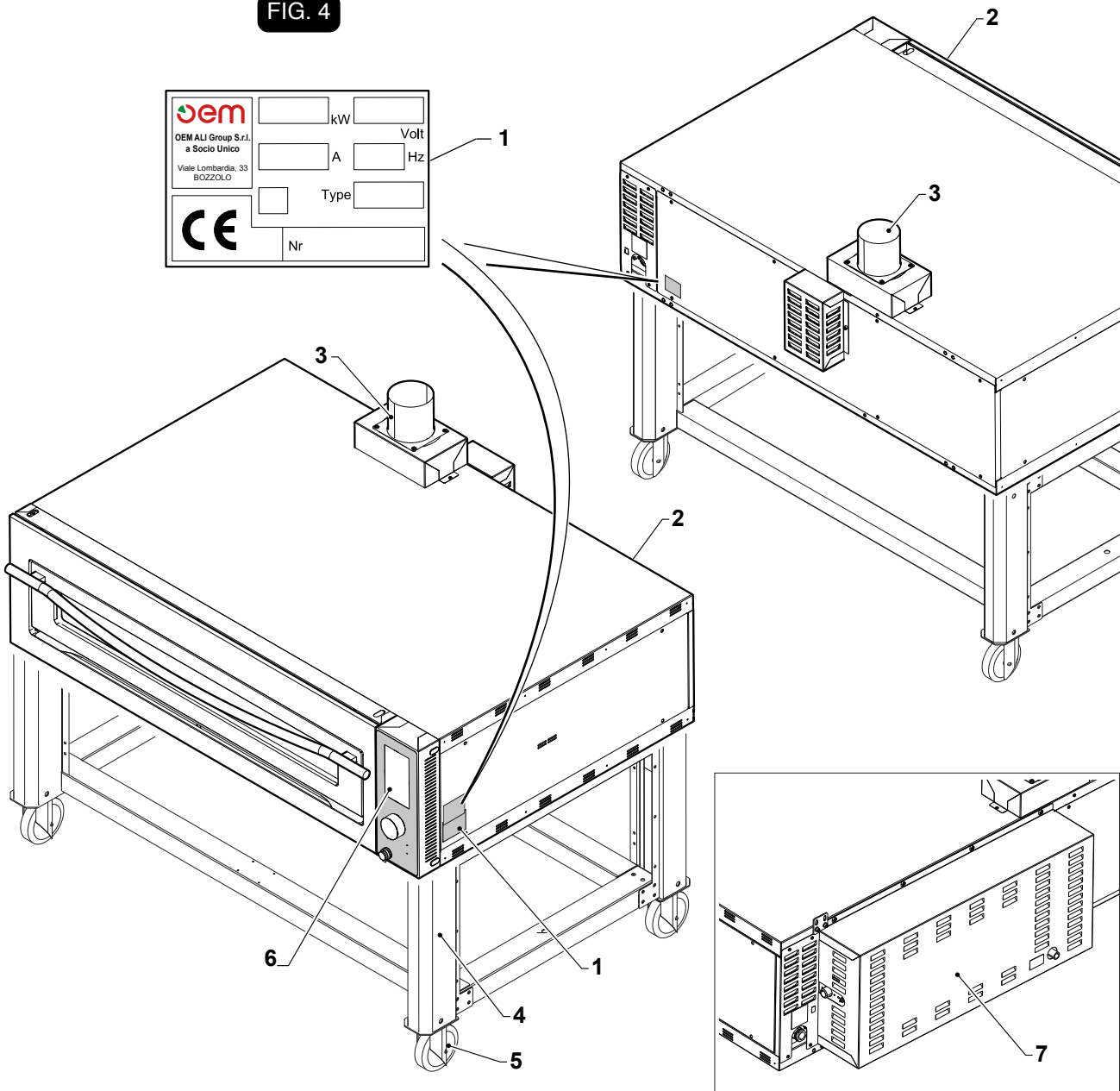

Chapter 3



DANGER

All operations described in this chapter shall be carried out by skilled and authorized technicians, only.

3.1 - UNIT LIFTING (Fig. 1)

Lift the unit through a suitable device, such as a crane or an hoist, complying with the following instructions:

- The oven shall slightly alternatively be lifted from its four sides using a lever and making sure the panels are not damaged, then the oven shall be positioned on shims (1).
- Insert the two belts (2), suitably dimensioned according to the weight of the unit, under the base (3) of the unit and connect them to the hook (4) of the crane or the hoist.

FIG. 1

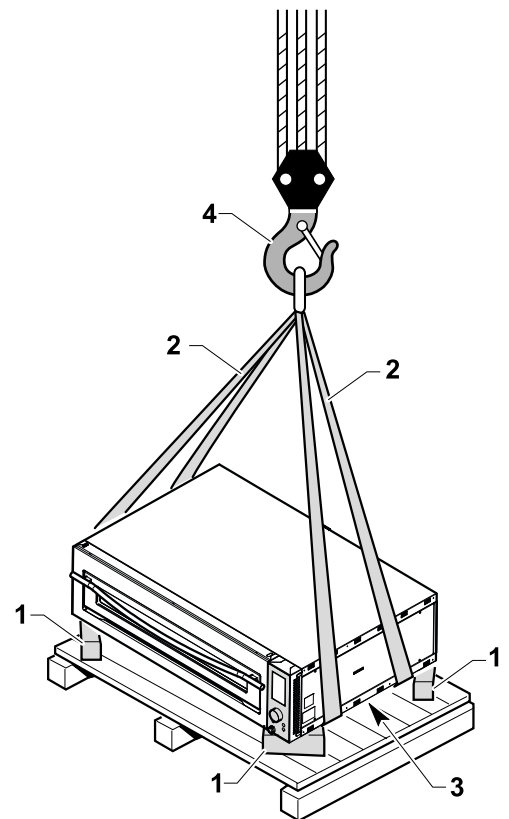

ATTENTION

To hoist the machine do not use steel belts as they may damage the outside body.

3.2 - VERTICAL HANDLING OF THE OVEN (Fig. 2)

- Remove the refractory surfaces.
- Position a pallet/trolley on the floor, etc.
- Turn the oven vertically so that the side with the control panel (1) faces upward.

FIG. 2

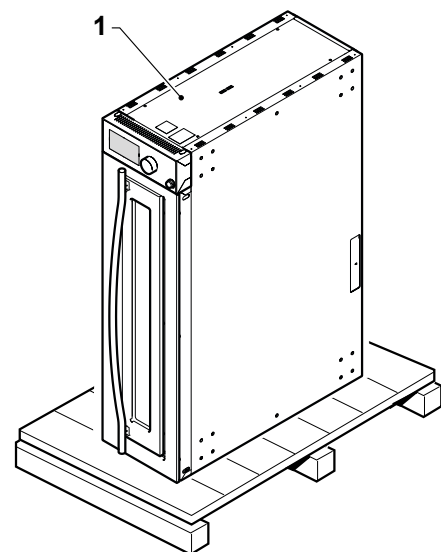

3.3 - ASSEMBLING OF THE COMPONENTS

Trailer-mounted support assembling



IMPORTANT

To mount the wheeled base unit, the instructions contained in the manual supplied with the latter shall be followed.

FIG. 3

Single-chamber oven assembling (Fig 3)

- Position the oven (1) on the base unit (2) and fix it by means of the two screws (3), on the right and the left side.

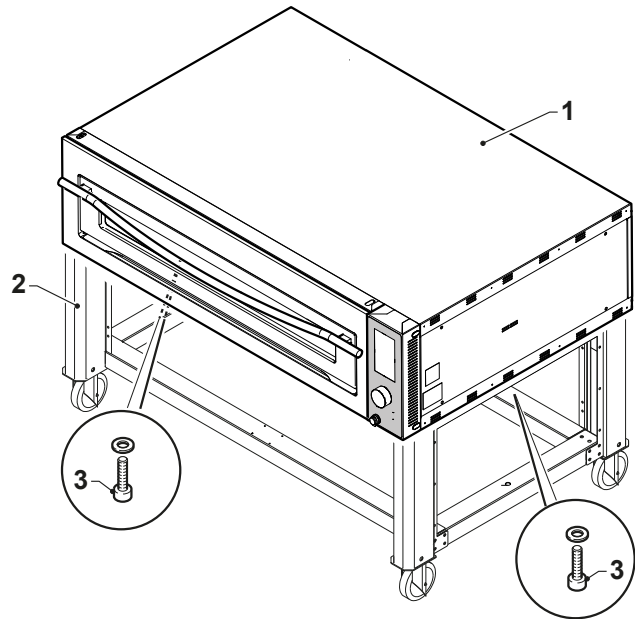

Two- and three-chamber oven assembling (Fig 4)

- In case of two-chamber ovens, the second oven (4) shall be positioned on the first one (1), after that fix both ovens by using the four-hole plates (5) and the relevant screws and washers.
- In case of three-chamber ovens, the third oven shall be positioned on the second one and fixed as mentioned in the previous item.

FIG. 4

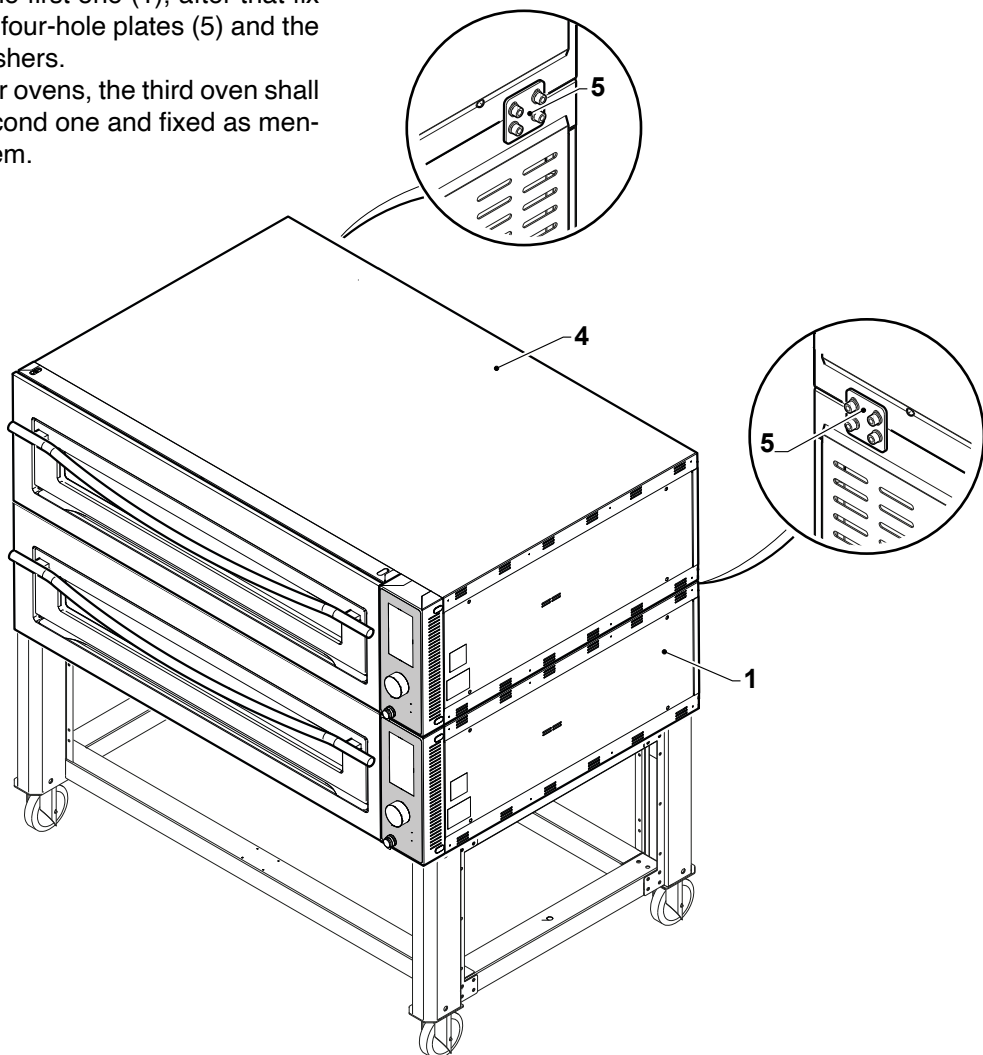

3.4 - ELECTRIC CONNECTION



- The power feed line should be provided with a suitable omni-polar **DISCONNECTING SWITCH** (automatic thermo-magnetic switch or differential) placed before the control unit main switch, with a minimum contact opening of 3 mm.
- The earthing system should comply with the local electric regulations in force.
- The electrical power cables are charged to the customer and they must be sized considering the maximum absorbed current. The type of cable must be a flexible cable under an oil-resistant sheath and must not be lighter than the polychromelene or synthetic elastomer cables under equivalent sheath (designation 60245 IEC 57) and it must comply with the rules in force in the country of use.
- The specifications of the electric power line should correspond to the specifications of the identification plate and to those mentioned in the technical specifications table that can be consulted in the first part of this booklet.



Before connecting the machine to the electric line, make sure that the **DISCONNECTING SWITCH** is disconnected (line not energized).



IMPORTANT

The line selector positioned upstream of the oven must be in an area easily accessible by the operator during all operation and maintenance of the oven.



In case of two- and three-chamber ovens, each oven shall be connected with a special knife switch, it is not possible to connect more than one oven to one knife switch.

3.4.a - Electric oven connection (Fig.5)

- Remove the cover (1) by undoing the screws (2).
- Connect the cable to the terminal board (3).
- Connect the phases to the terminals L1, L2 and L3, the neutral wire to the terminal N, the earth to the terminal T.
- For areas where the automatic load distributor is present, connect the two 12V power supply wires to "SAFE" terminals.
- Remount the casing (1).

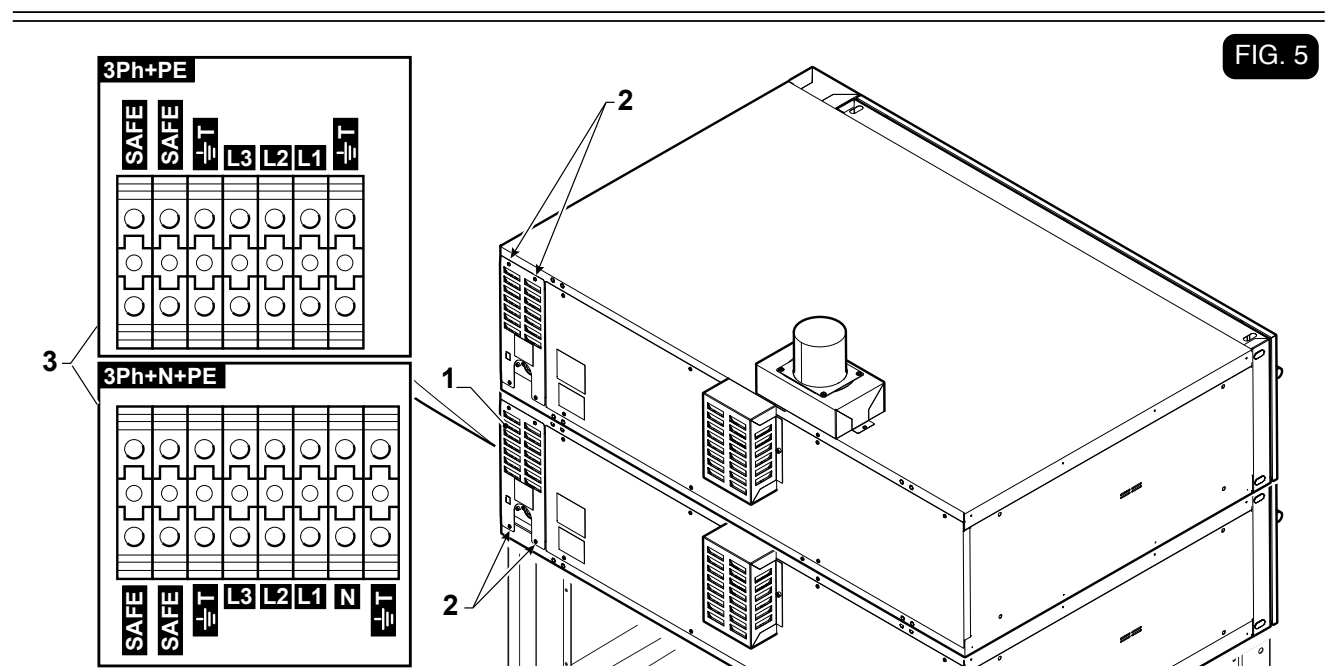

FIG. 5

3.4.b - Unipotential connection (Fig 6)

The equipment shall be inserted in a unipotential system, whose effectiveness shall be verified according to the rules being in force.

Remove the cover (1) by undoing the screws (2) (Fig. 5). A cascade connection shall be carried out among the various oven components by using the screw (3) placed on the rear oven side.

FIG. 6

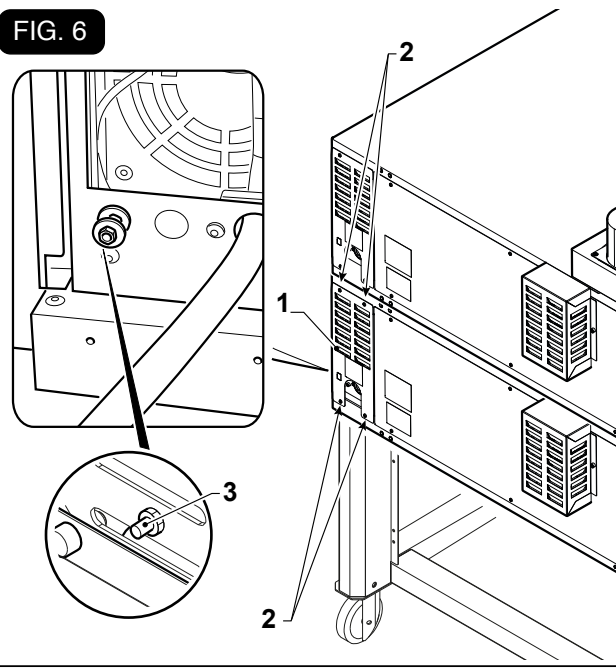

3.5 - OVEN POSITIONING (Fig 7)



The oven shall NOT be installed closed to inflammable walls such as furniture, partition walls, matchboarded coatings etc...

A safety range of at least 50 mm from lateral and rear oven sides should be kept.

No inflammable flooring shall be utilized to install the oven on it.



IMPORTANT

In case the oven shall be built in, there shall be a suitable change of air on its rear side and this can be obtained by means of air grilles (1) placed on the wall.

- The oven shall be positioned on the final area following the indications reported in figure 7, because they indicate the minimum distances required to allow the oven correctly to function.
- The oven should be placed where there are no turbulence or air currents, dust, leak-derived liquids or condensation or aerosols because they would adversely affect the food and change the good functioning of the baking chamber and therefore of the finished product, this condition also significantly increases the consumption of electricity.
- Fix the oven position by braking the rear wheels.

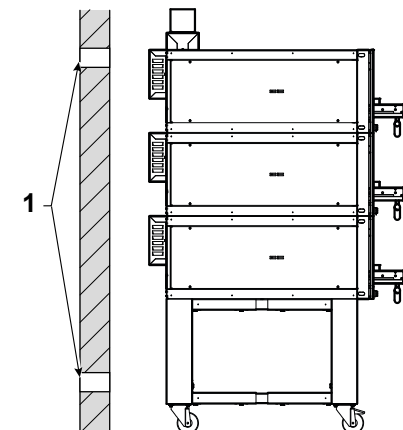
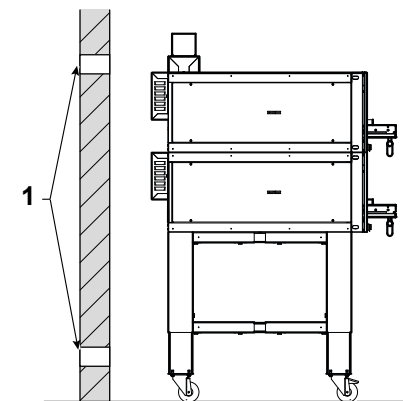
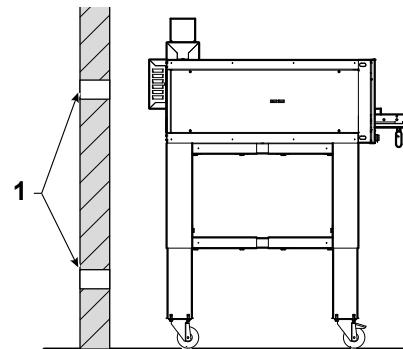

FIG. 7

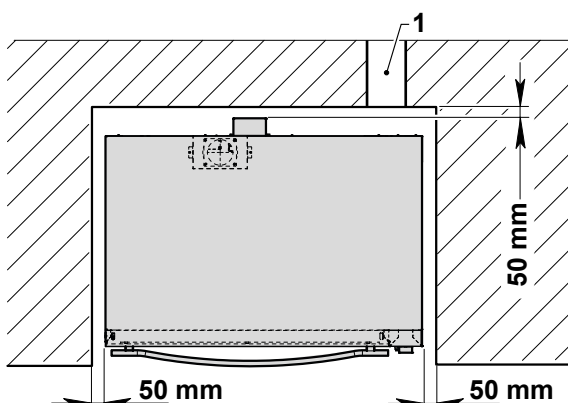

FIG. 8

3.5.a - Assembling the chimney (Fig. 8)

- Assemble the box (1) on the top part of the oven, screwing it in with screws (2)
- Assemble the chimney (3) locking it onto box (1) by means of plate (4) with screws (5).



IMPORTANT

The chimney must be assembled on the last top oven.

- Connect the chimney (3) to a flue by means of a pipe with diameter of 120mm.

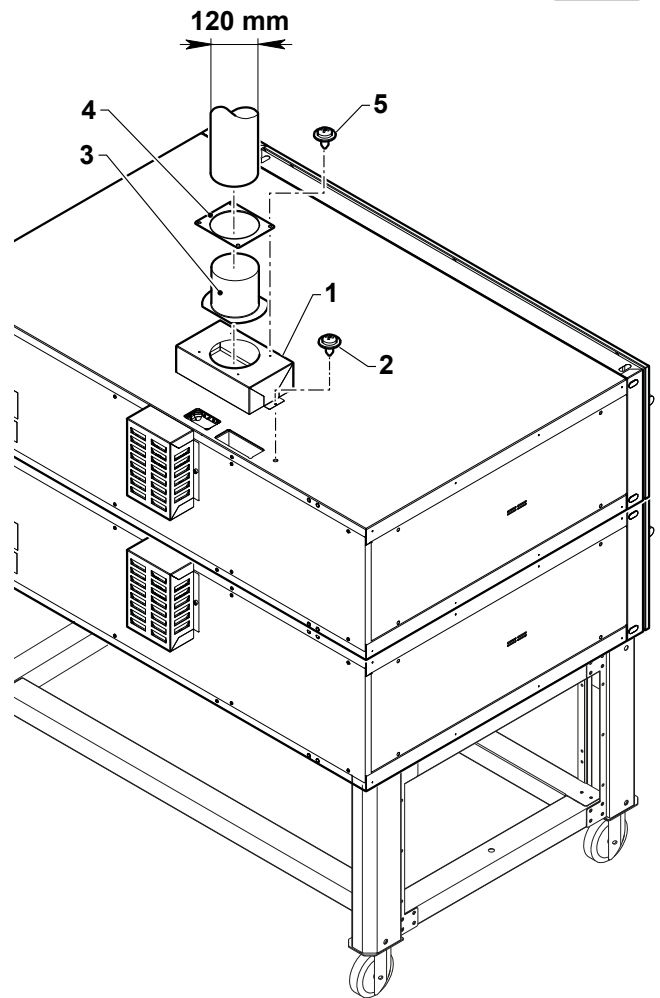

3.5.b - Water connection (only for steamer) (Fig. 9)



IMPORTANT

It is recommended to feed the steamer with demineralized water to minimize the creation of limestone inside the vaporizer.

Load

- Connect the water supply pipe to the 3/4" junction of the electrovalve.

Exhaust

- Connect the flexible exhaust pipe to the 21 mm diameter junction (2) and fix it with a band.



IMPORTANT

After having carried out the water supply fitting open the water supply tap and check that there is no water loss.

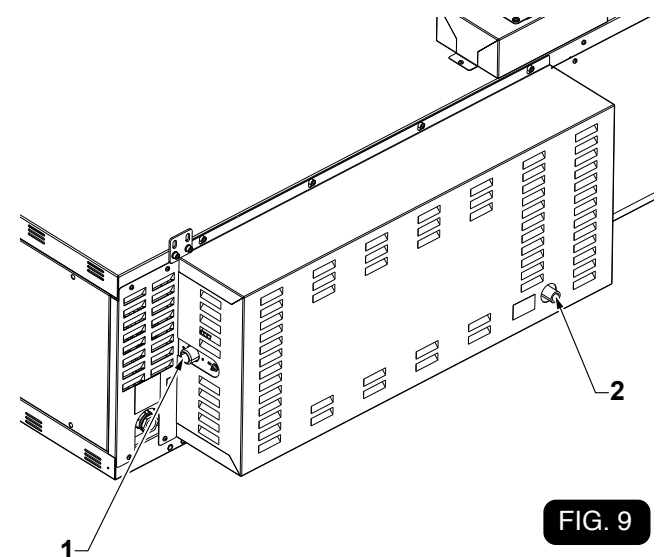

FIG. 9

Chapter 4

4.1 - INTENDED USE



IMPORTANT

SUPER TOP ovens are professional machines suitable for baking pizza and similar products.

The various models shall only be used to process as above;

IN CASE OF ANY OTHER USE, MANUFACTURER DISCLAIMS ALL RESPONSIBILITY FOR ACCIDENTS TO PERSONS OR OBJECTS AND CUSTOMER WILL BE DEBARRED FROM A POSSIBLE GUARANTEE RIGHT.

4.2 - IMPROPER USE

The SUPERTOP - SUPERTO VARIO oven models have been designed and constructed exclusively for food use and the following is hence prohibited:

- For non-professional operators to use the oven.
- Heat liquids, drinks or other substances.
- Insert non-food products.
- Insert flammable materials.

4.3 - SAFETY PLATES (Fig. 1)

The warning plates with explanatory symbols are to be found in all those areas that may be dangerous for operators or engineers.



DANGER

Anyone preparing to work on the machine should protect the warning plates with the safety instructions. The non compliance with the instructions mentioned on the safety plates will release the manufacturer from all responsibilities for damages or injuries to persons or properties that may arise.

Danger: machine under voltage

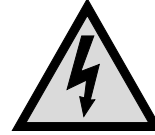

- Do not work with the machine under voltage.

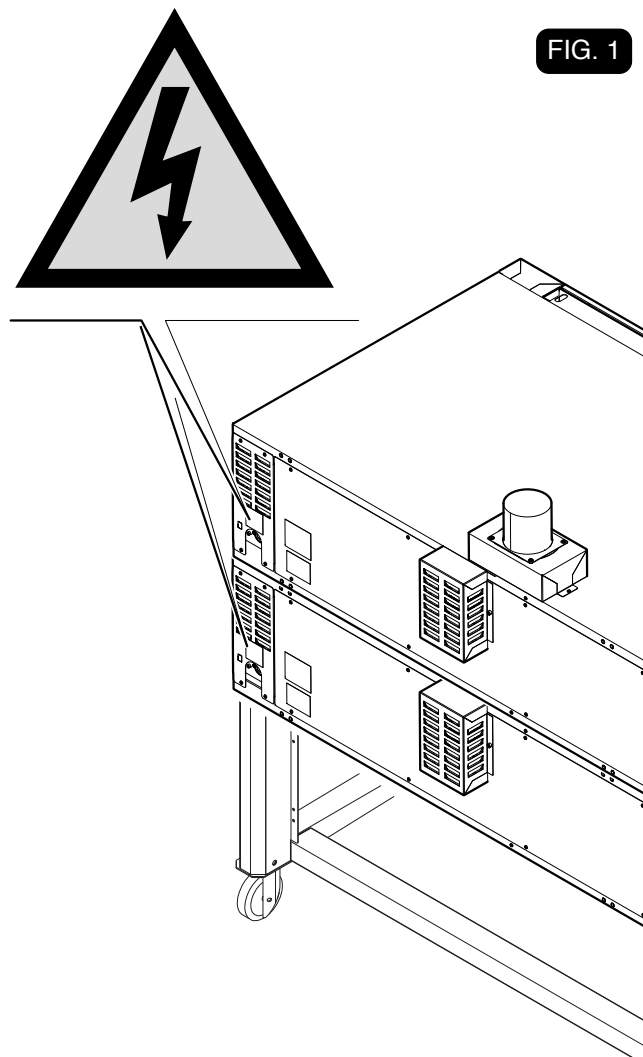

FIG. 1

4.4 - SAFETY DEVICES

The equipment is equipped with following safety systems:

- 1) All dangerous areas are closed by screwed cases.
- 2) Each oven is equipped with a safety thermostat, which disconnects the oven in case of overtemperature inside the baking chamber, in case of digitally controlled ovens, the card is equipped with a special component, which stops the oven functioning in the event the temperature inside the control board exceeds 85°C.
- 3) If the steamer is present, it is equipped with a safety thermostat that turns off the steamer in case of overtemperature detected inside the same.

4.5 - USER'S AREAS (Fig 2)

During the oven functioning, user is in front of it, in order to be able to easily insert and remove the pizza through the door (1) (see Fig. 2 "O" position).

To carry out maintenance operations, technician's position may be on the rear or lateral side of the oven "T" position.

4.6 - RESIDUAL DANGER AREAS (Fig. 2)

The residual danger areas are those areas that cannot be protected because of the particular type of production, as far as the machine concerns. They are the following:

- Door area and baking chamber inner area: risk of burns.

4.7 - DANGER ZONES

The danger zones (1) are all those where the protection panels are removed while the oven is working during its repair operations and **MAY ONLY BE ACCESSED BY THE MAINTENANCE TECHNICIAN.**

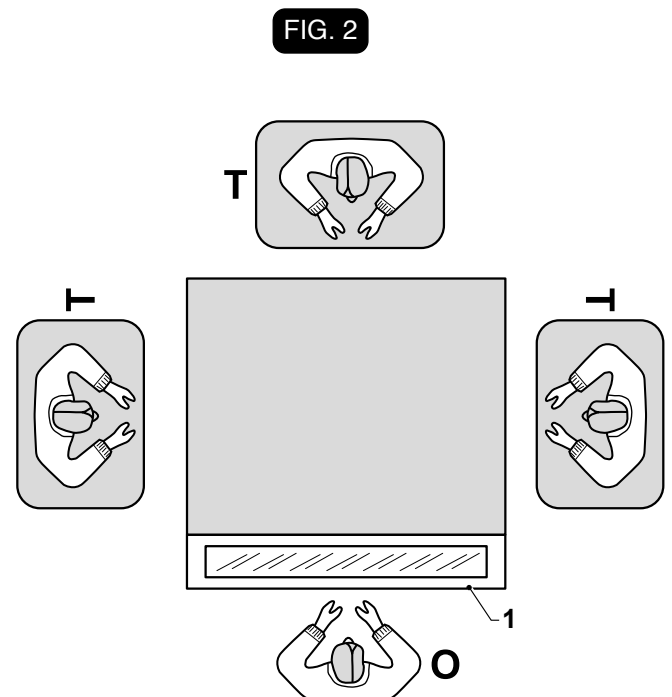

Chapter 5

For all ompositions, oven functioning is single, therefore it is possible to set two or three different baking programmes in case of two- or three-chamber ovens, pizza shall be positioned according to the concerned oven model as reported in following figure:

Mod. **635 L** can contain 6 pizzas Ø 30 or Ø 35 cm, 2 pizzas Ø 45 cm or 2 baking trays 60x40 positioned as follows:

SUPERTOP

Mod. **435** can contain 4 pizzas Ø 30 or Ø 35 cm, 1 pizza Ø 45 cm or 1 tray 60x40 cm positioned as follows:

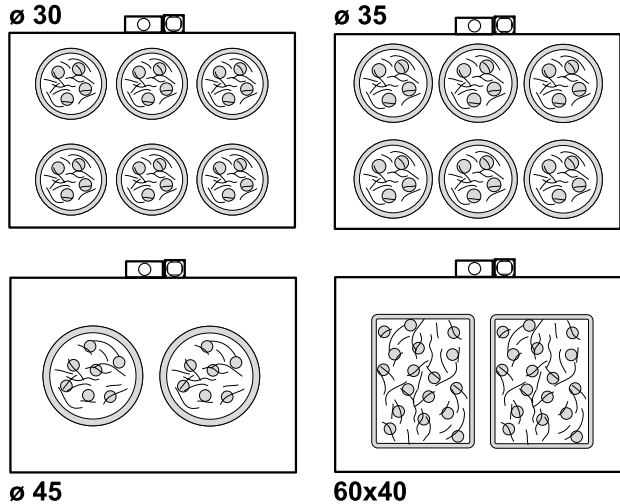
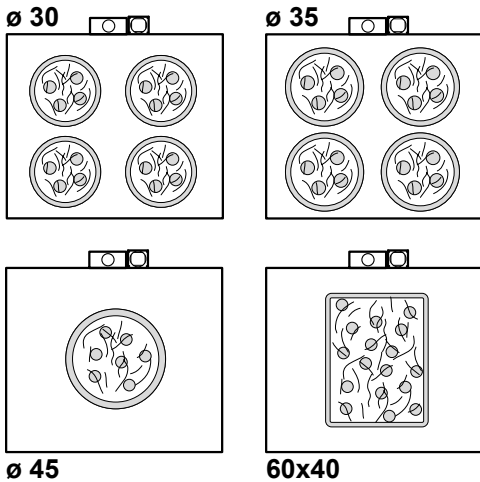

Mod. **935** can contain 9 pizza sØ 30 or Ø 35 cm, 4 pizzas Ø 45 cm or 4 baking trays 60x40 cm positioned as follows:

Mod. **635 S** can contain 6 pizzas Ø 30 or Ø35cm, 2 pizzas Ø 45 cm or 2 baking trays 60x40 positioned as follows:

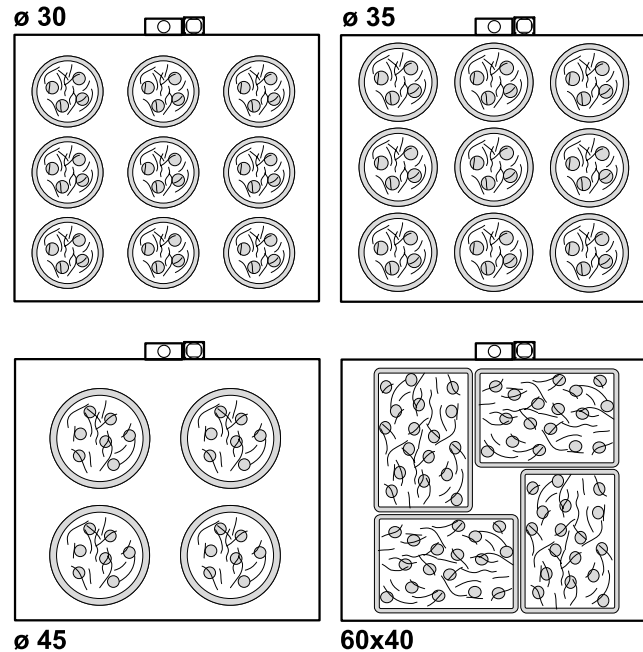
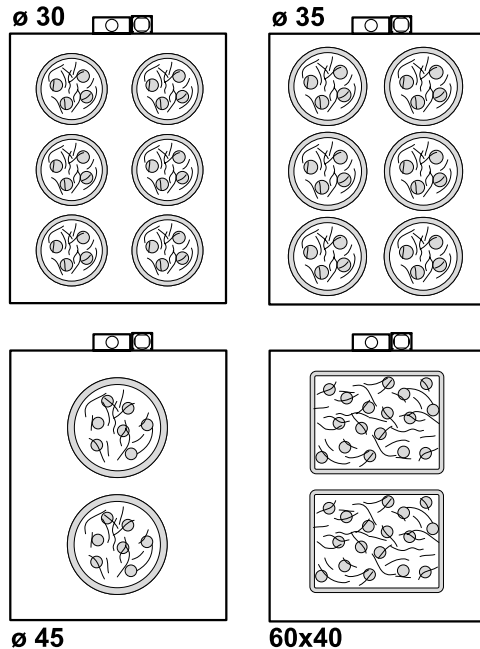

SUPERTOP VARIO

The Mod. **440** can contain 4 pizzas of Ø 40 cm or 2 60x40 cm baking trays positioned as the following scheme.

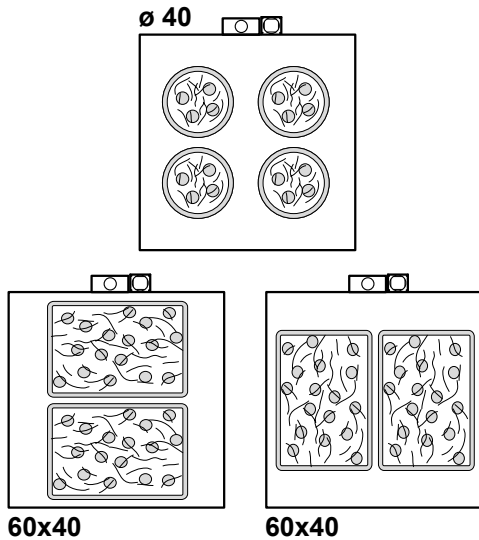

The Mod. **640 L** can contain 6 pizzas of Ø 40 cm or 4 60x40 cm baking trays positioned as the following scheme.

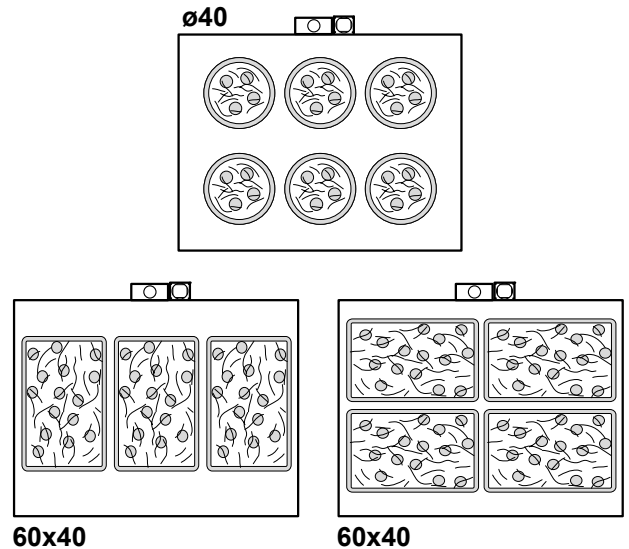

The Mod. **640 S** can contain 6 pizzas of Ø 40 cm or 3 or 4 60x40 cm baking trays positioned as the following scheme.

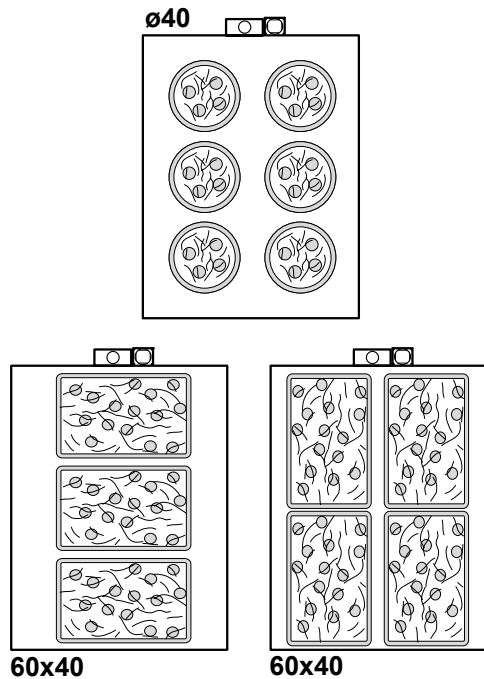

The Mod. **940** can contain 9 pizzas of Ø 40 cm or 6 60x40 cm baking trays positioned as the following scheme.

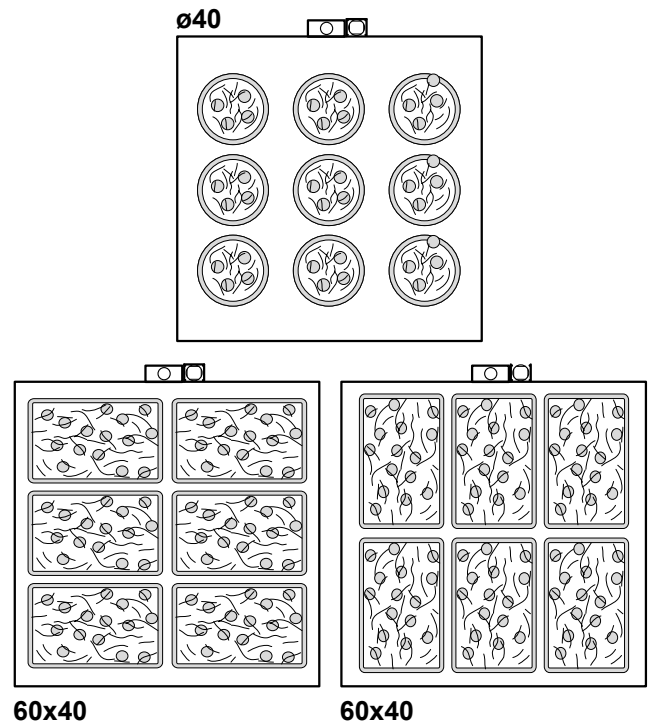

FIG. 1

5.1 - OVEN CONTROL PANEL TOUCH (Fig. 1)



IMPORTANT

All the functions available via contact on the display (TOUCH SCREEN) can also be selected by turning and pressing the dedicated selection knob (2).

The following controls are located on the oven::

1. Display

All functions related to oven operation are shown on the display, with alarms, settings etc.

2. Encoder push knob

This knob can be used to scroll settings on the display. Press it to select, edit and confirm settings.

3. Power button (On/Off)

Press to supply or cut off voltage to the controls.

4. USB port

This can be used to upload and download files using a USB flash drive (software, recipes, settings etc.), only if the oven is disconnected from the internet.

5. "Timer 1" button

The "Timer 1" button can be set independently for all baking programs.

Press the button to enable the baking time for the selected program; this time can be paused or reset by pressing this button for a few seconds.

6. "Timer 2 / Steamer" button

- Timer Function

The "Timer 2" button can be set independently for all baking programs.

Press the button to enable the baking time for the selected program; this time can be paused or reset by pressing this button for a few seconds.

- Steamer Function

For the models equipped with a steamer, with an active steamer, it controls the injection of steam.

Pressing and holding down the button you activate the steam injection for the maximum set time.

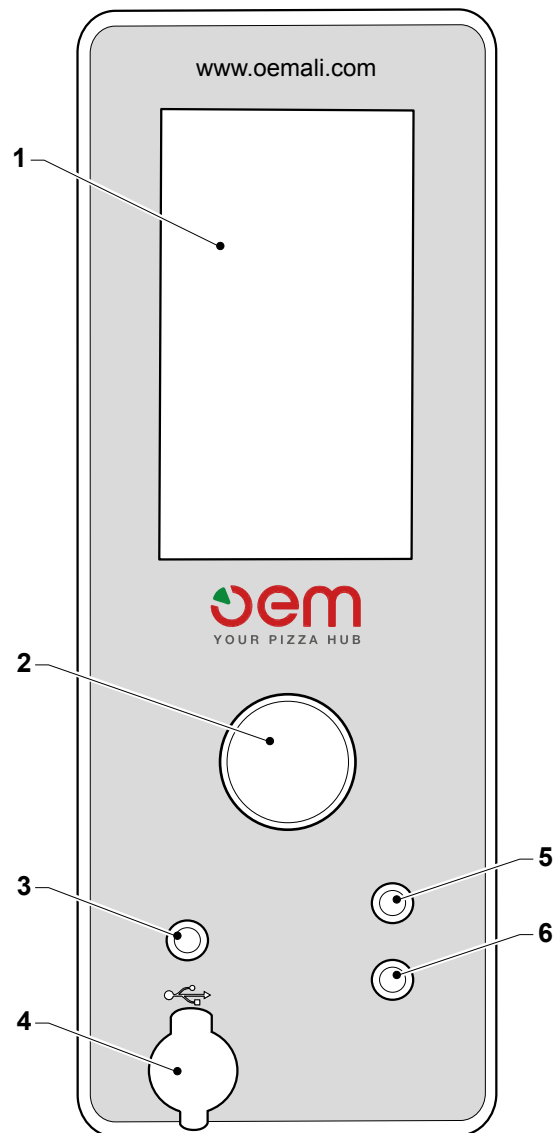

FIG. 2

5.2 - USER INTERFACE (Fig. 2)

The following appears when the display oven is switched on:

- 1. Calendar**
This shows the day of the week, the month and the year.
- 2. Language**
A flag is used to view the set language.
- 3. Time**
This shows the hours and minutes.
- 4. Scheduled start-up**
If the schedule start-up function is set, the day of week and start-up time are displayed.
- 5. Software versions**
This displays the display software version (5a) and the power board software version (5b).



FIG. 3

5.3 - MAIN SCREEN (Fig. 3)

After starting the oven, the main screen used by the user is as follows:

1. Temperature

This shows the current temperature in the chamber

2. Ceiling heating element

This displays the set percentage of the Ceiling heating elements, if the heating element is operating, LED (2a) will turn on in red.

3. Set temperature

This displays the set baking temperature (Set Point) for the selected program and for manual operation.

4. Floor heating element

This displays the set percentage of the Floor heating elements, if the heating element is operating, LED (4a) will turn on in red.

5. Chimney

This shows the chimney opening percentage for extracting fumes and baking steam; settings are: 0, 25%, 50%, 75%, 100%

6. Extractor

This shows the fan speed percentage for extracting fumes and baking steam; settings are: 0, 25%, 50%, 75%, 100%

7. Timer 1

This shows the set baking time of the first timer set for the selected program.

8. Timer 2 / Steamer

It displays the baking time of the second timer set for the selected program. If the steamer is on, display:

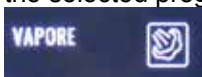

where it is indicated if the steamer has reached the set temperature with a green tick, a necessary condition to trigger the injection of steam.

9. Programs

It displays the settable baking program, if active the icon is red.

There are 8 main modes, with 3 programs each, for a total of 24 programs that can be set.

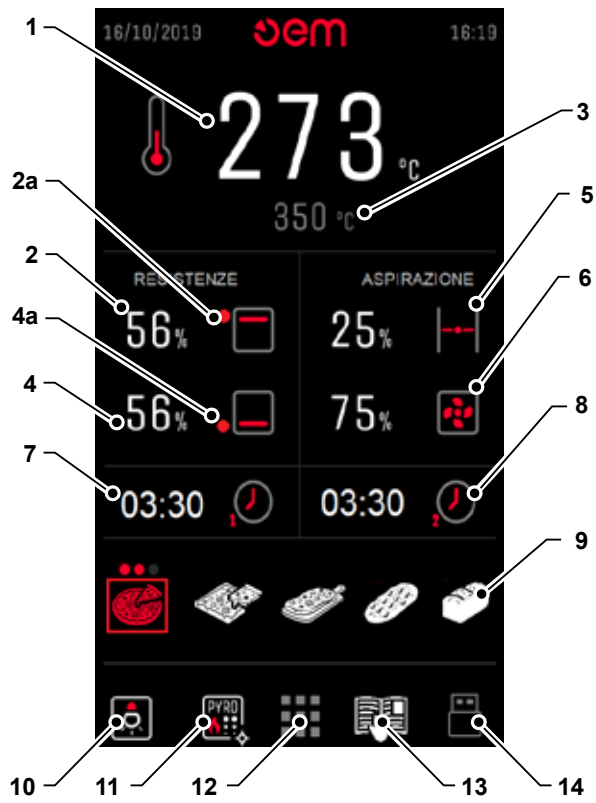

10. Lamp

It displays the status (on/off) of the lighting in the baking room.

11. Self-cleaning cycle

This allows access to the pyrolysis program for the self-cleaning of the baking chamber.

12. User Menu

It allows you to enter the user menu.

13. Recipe Menu - Manual

It allows you to enter the list of recipes and consult the oven manual.

14. Use USB

This allows accessing the menu to use the USB port and to display recipes.

















5.4 - SELECTING PROGRAMS OR CHANGING PARAMETERS (Fig. 4)

In the main and secondary screens of the User Menu it is possible, by pressing on the Touch display, to modify the oven cooking parameters..

5.5 - PROGRAMMING BAKING PARAMETERS

The oven can be used either manually or through the respective baking programs. Each of the eight baking programs has three possible settings, for a total of 24 settings.

The editable parameters are the following:

-  Ceiling heating element power %
-  Baking temperature
-  Floor heating element power %
-  Chimney opening %
-  Suction fan speed %
-  Baking time 1
-  Baking time 2
-  Classic pizza program
-  Pizza in backing tray program
-  Pizza on shovel program
-  Focaccia program
-  Bread program
-  Program P1
-  Program P2
-  Program P3
-  Cooking assistance

For example, to vary the cooking temperature you need to:

- Press on the display in the temperature area (1) - Fig. 5a.
- Change the temperature value using the "+" (1) and "-" (2) buttons - Fig. 5b.
- Press the "Back" button (3) to confirm the value (Fig. 5b).



FIG. 4



FIG. 5a

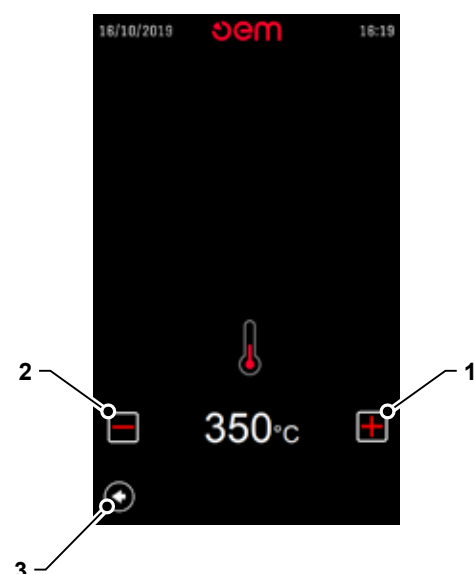

FIG. 5b

To store the desired value in a program:

- Press on any program to enter the save page (1) - Fig. 5c.
- Press on the desired program: press the program icon several times to select one of the three subprograms (1) - Fig. 5d.
- Press and hold the "Save" button (2) - Fig. 5d, until an acoustic signal sounds. Once stored, on the main screen, the icon stops flashing.



FIG. 5c

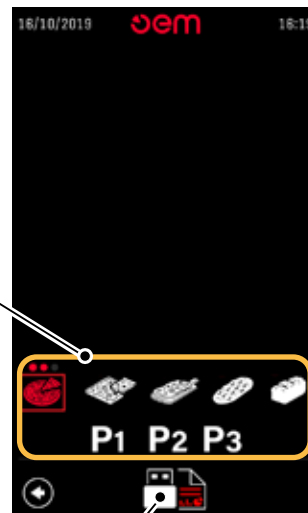

FIG. 5d

5.6 - CHAMBER LIGHTING (Fig. 6)

The oven is provided with two lights (one on each side) to be able to illuminate the baking chamber.

By pressing the respective icon on the display you can turn the lamps on or off:

- Lamp on (1);

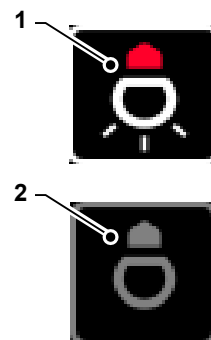



FIG. 6

- Lamp off (2).

5.7 - USER MENU (Fig. 7)

To access the user menu, press the “

This menu can be used to select and set all functions on user level. It is possible, by pressing on the icons on the display, to set the relevant parameters:

1. LANGUAGE

This can be used to set the language by selecting the respective flag.

2. CALENDAR

The current date and time can be set.

3. AUTO POWER-ON TIMER

The time, date and program for automatic power-on of the oven can be set.

4. COOKING ASSISTANT

You can access the cooking assistant setting page.

5. ECO MODE

The oven switches to ECONOMY mode after a certain time (programmable). The chamber light is switched off, the chimney is closed and the temperature is maintained in the chamber. Baking settings are resumed when the oven door is opened.

6. DOOR FUNCTIONS

The following functions may be performed automatically when the door is opened:

- Ceiling heating elements at 100% on to prevent temperature drops (6a).
- Enable a warning buzzer if the door remains open for more than one minute (6b).
- Set an operating time of the extractor at maximum speed to remove baking steam after the product is taken out of the oven; the time can be set between 0 and 25 seconds (6c).
- Set a delay time to open the chimney after the door is closed (product in oven) (6d).



IMPORTANT

The enabled functions will have the word “ON”, those disabled the word “OFF”.

7. USER MENU EXIT

To exit the user menu, select the icon (7).

8. USER DATA RESET

To reset all data and return to factory settings, select the icon (8) pressing for 5 seconds.

9. SERVICE MENU

This menu is for “OEM” or specialised personnel use only and is password-protected.

FIG. 7

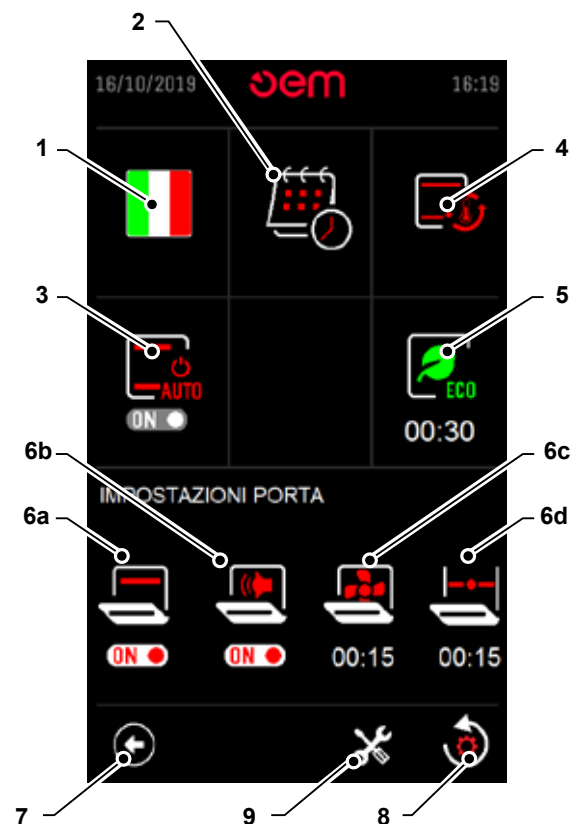

5.8 - AUTO POWER-ON TIMER

The auto power-on timer can be set from the user menu by means of icon .

This menu can be used to set to switch the required program on twice every day (Fig. 8a).

1. Days of the week column

This displays the days of the week the oven turns on.

2. TIME OF FIRST SWITCH ON

This field is used to set the time to turn the oven on for the first time.

3. FIRST IGNITION PROGRAM

The number of the program selected for the first power-on must be entered in this field.

4. TIME OF SECOND IGNITION

This field is used to set the time to turn the oven on for the second time.

5. SECOND IGNITION PROGRAM

The number of the program selected for the second power-on must be entered in this field.

6. SELF-POWER ON/OFF

You can turn self-power on or off without canceling your daily settings, acting on the icon (6); when the self-power is enabled on the icon will display the word "ON", with the word "OFF" the self-power is disabled.

If the time is not shown, but --:-- is displayed, that day is skipped.

When the oven is off, the power-ons set for the day are shown (Fig. 8b).

7. Day, date and time of first power-on (Fig. 8c)

8. Day, date and time of second power-on (Fig. 8c)

Select icon (9) to quit the auto power-on screen (Fig. 8a).

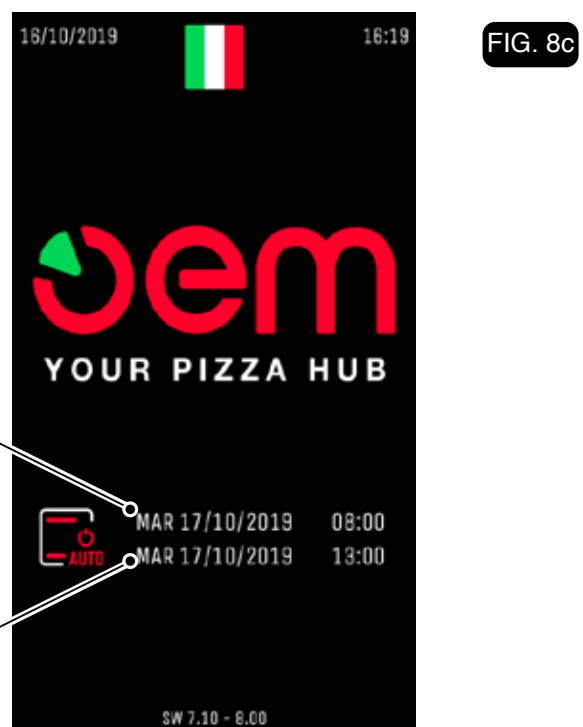
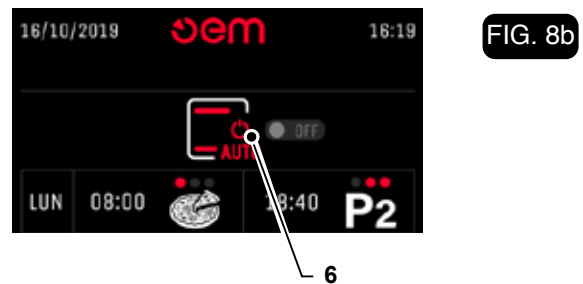
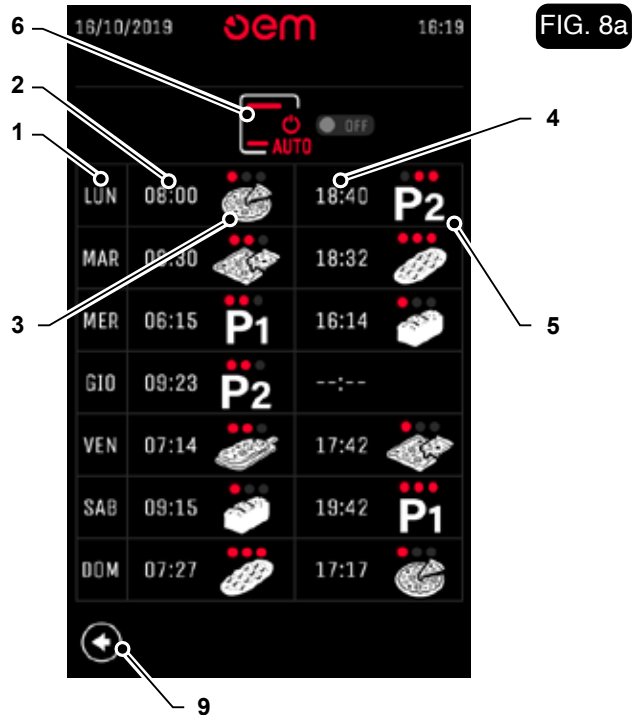

5.9 - CALENDAR (Fig. 9)

From the user menu you can access the calendar setting by selecting the "📅" icon.

1. Day of the week

Select this field to set the day of the week.

2. DATE

Select this field to set the day, month and year.

3. TIME

Select this field to set the hours, minutes and seconds.

Press icon (4) to quit the calendar screen.

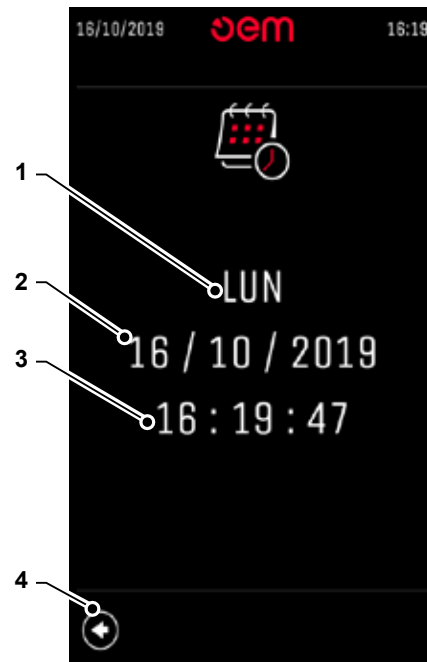

FIG. 9

5.10 - COOKING ASSISTANT (Fig. 10)

From the user menu you can access the cooking assistant setting by pressing the appropriate icon "🔧".

The cooking assistant is a function that ADJUSTS the oven's performance according to productivity: when the cooking chamber temperature drops compared to the set temperature, the cooking assistant will intervene (based on the set parameters).

1. Temperature difference

Press on the display (pos. 1) to set the temperature difference at which the cooking assistant will intervene.

2. Percentage of Upper Resistances

Press on the display (pos. 2) to set the additional percentage of the upper resistances when the cooking assistant is **active**.

3. Percentage of Lower Resistances

Press on the display (pos. 3) to set the additional percentage of the lower resistances when the cooking assistant is **active**.

Once you have set the desired parameters, press the back button (4) to confirm.

COOKING ASSISTANT NOTES

1. Each program has its own dedicated settings for the cooking assistant, therefore they can be stored within each program.
2. It is necessary to maintain a certain "margin" for the resistance percentages, otherwise the function is ineffective.
3. The sum of the percentages on the main screen plus that of the cooking assistant can be a maximum of 100%.

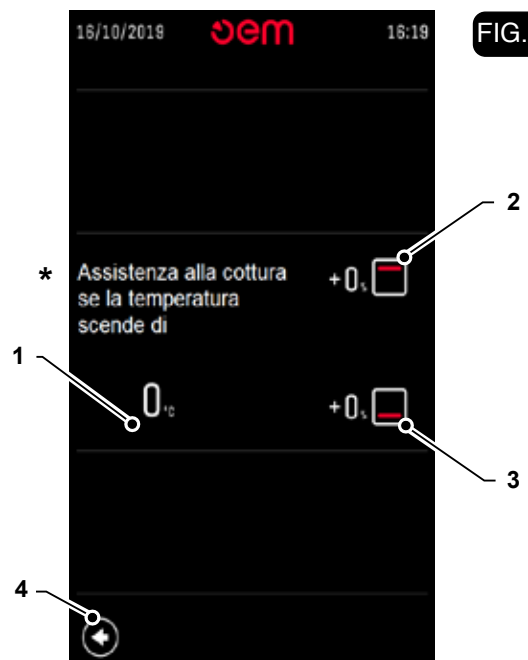



FIG. 10

* COOKING ASSISTANCE if the temperature drops by...

5.11 - DISPLAYING RECIPES AND MANUAL

In this part of the menu you can view the recipes and the manual contained in memory. Press on icon  and you will access the display page (Fig. 11).

1. Recipes

Pressing you can enter the archive of stored recipes.

2. Manual

Pressing you can consult the oven manual.

3. QR Code

By scanning the QR Code, you are redirected to the oven's use and maintenance manual.

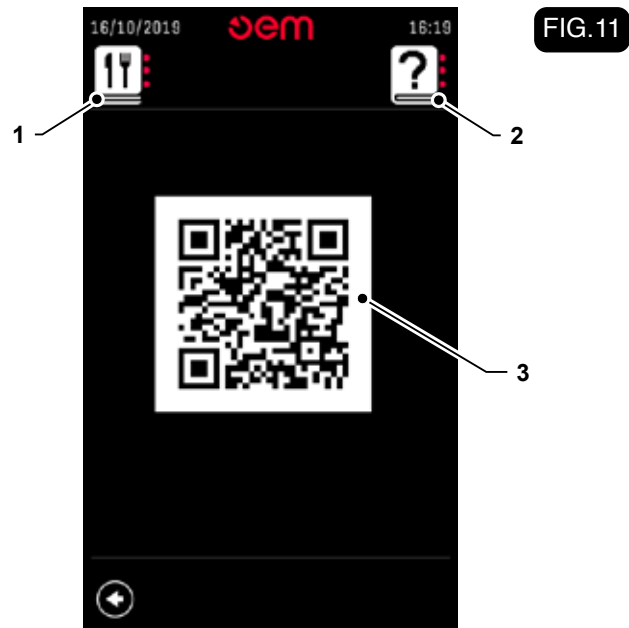

5.11a - USB PORT

The oven is fitted with a USB port to perform the following operations, only if the oven is disconnected from the internet.:

- Uploading/downloading recipes;
- Downloading a log file for the oven;
- Uploading/downloading the software for oven operation with the settings of the user and service interfaces.

To access the page, press on the icon  and the screen will be displayed (Fig 12):

- 1) Recipe Download
- 2) Recipe Upload
- 3) Manual Download
- 4) Manual Upload
- 5) Oven software and user and service settings Download
- 6) Oven software and user and service settings Upload
- 7) Download of the oven datalog, containing the history of the activities of the oven.
- 8) USB key insert icon: With an inserted and compatible stick, the green tick is displayed.

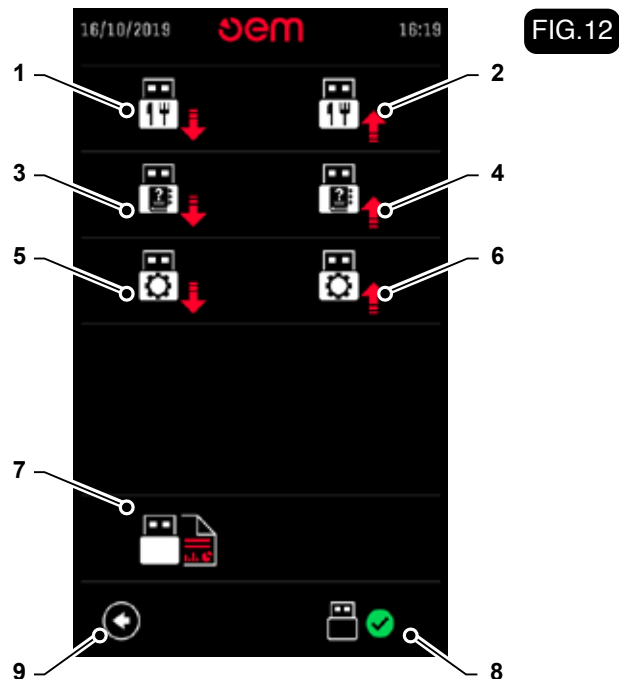

To exit the USB screen, press the icon (9).

To make the download on the stick:

- Inserting an empty stick into the USB port the icon changes from  to  indicating that you can download it.

• Press:

- (1) If you want to download recipes
- (3) If you want to download the manual
- (5) If you want to download the software
- (7) If you want to download the datalog



- The icon flashes for as long as the download occurs.
- When the download is complete, the icon stops blinking: it is possible to remove the stick



IMPORTANT

Do not pull out the USB stick until the download is complete.

To make the UPLOAD from the stick:

- Insert a stick that contains the information you want to upload (recipes, manual, software) into the USB port: the icon changes from  to  indicating that you can upload.

• Press:

- (2) If you want to upload recipes
- (4) If you want to upload the manual
- (6) If you want to upload the software

The icon flashes for as long as the upload occurs.

- When the upload is over, the icon stops blinking: it is possible to remove the stick



IMPORTANT

Do not pull out the stick until the upload is complete.

5.12 - RECIPE ENTRY MODE

The following PC programs are required to use this function:

- Paint (Windows app)
- IrfanView 64 (free download from the INTERNET)
- Open "Paint" and create an image with size of 480

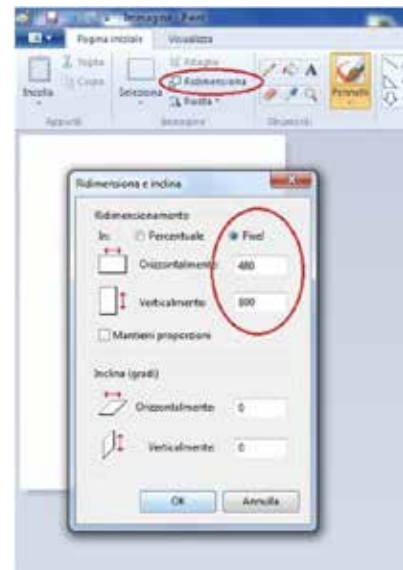

by 800 pixel.

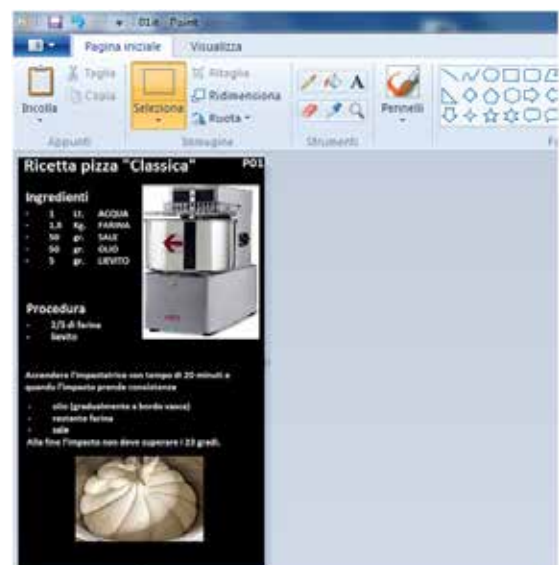

- This program is used to write and insert images.
- Save the image in the "recipe" folder (created for this purpose) with the page number and relevant language, e.g. : "01it" 24 bit bitmap up to a maximum
- Start "IrfanView 64" and open the file that was just created.
- Select the following on the tool bar:

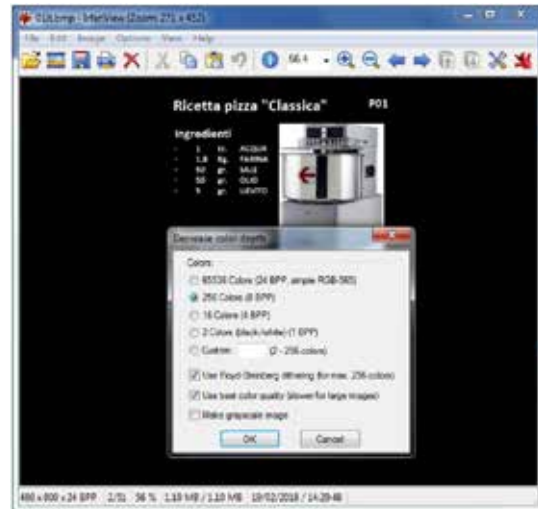

of 51 pages (from 00it to 50it).



Image, Decrease color depth and set 256 Colors (8 BPP).

- Now the image is converted and can be saved. Select File, Save as... on the tool bar and save it in the "recipe" folder, overwriting the original.

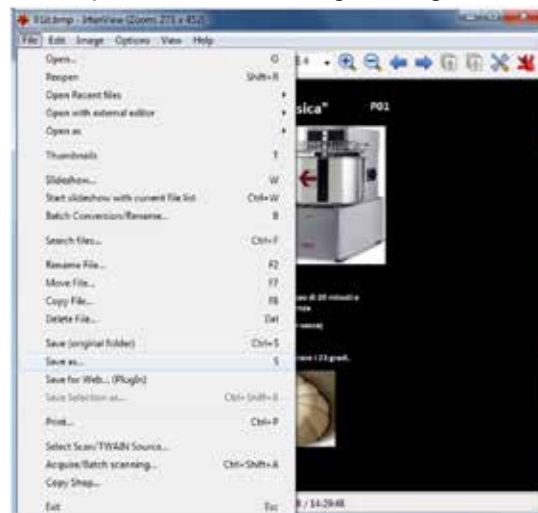

Functioning



This procedure must be repeated for each image.

- Put the recipe folder (containing converted files) in a USB flash drive (compatible with the system).
- Turn on the oven and access the relevant USB menu



FIG. 14

with button (1) (Fig. 13).

- Insert the stick in the appropriate enclosure and wait for the icon (2) becoming from “” to “”
- Press the icon (3) that starts blinking. You will see a scan of all Files (01it, 02it, 03it, etc.) and at the end the oven will take you to the main screen.

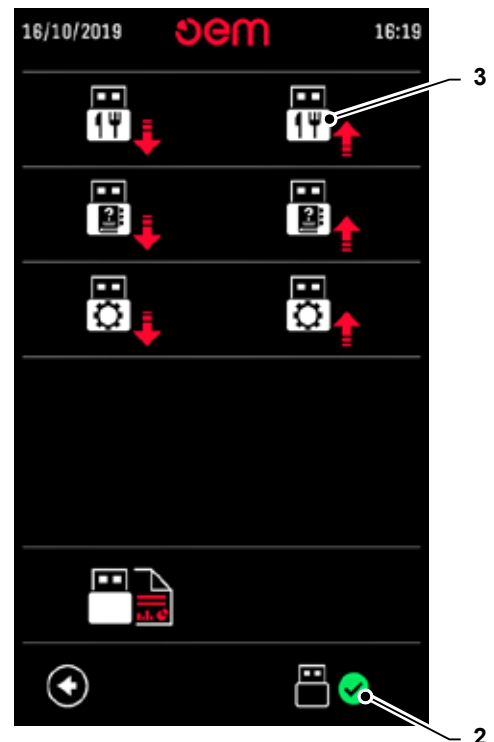

5.13 - OVEN PREPARATION

Pizza can be baked as follows: either directly on the refractory surface or in the baking tin.

Following a few information on the adjustment of the different parameters, however for more detailed information, refer to the paragraph “**Pizza cooking**”.



IMPORTANT

The information reported in the table shall be followed until the user’s experience allows the user to personally set time and temperatures.

5.13.a General rules to bake on refractory surfaces

- Start the oven at least one hour and fifteen minutes before working and set following parameters. The different programs in the oven are already set as described in the next table.
- The table contains some baking time values to be set according to the type of baking you have to consider. The indicated baking time is approximate, because it can depend on the different existing conditions (type

of dough, temperature, etc..)



IMPORTANT

Parameters can change according o the type of pastry used.



ATTENTION



- Do not salt the refractory surface, do not make the surface cool using a wet cloth with cold water, only use pizza dough; in this way, a refractory surface wear does not occur and pizza can correctly

Program	Baking type	Program Intensity	Temperature	Time
Classic pizza	Refractory	•	330	3,5 min
		• •	330	3,5 min
		• • •	330	3,5 min
Pizza in a baking tray	Baking tray	•	300	8 min
		• •	300	8 min
		• • •	300	8 min
Pizza in shovel	Refractory	•	300	6 min
		• •	300	6 min
		• • •	300	6 min
Focaccia	Baking tray	•	280	12 min
		• •	280	12 min
		• • •	280	12 min
Bread	Refractory	•	210	45 min
		• •	210	45 min
		• • •	210	45 min
P1	Refractory	•	330	3,5 min
		• •	330	3,5 min
		• • •	340	3,5 min

Program	Baking type	Program Intensity	Temperature	Time
P2	Refractory	•	305	4 min
		••	305	4 min
		•••	315	4 min
P3	Baking tray	•	300	6 min
		••	300	6 min
		•••	310	6 min

be baked, as well.

5.13.b General rules to bake in baking-tin

- Start the oven at least one hour and fifteen minutes before working and set following parameters:
Working temperature 300°C
Ceiling resistance 50%
Bedplate resistance 60%
Chimney closed "0".

5.13.c General cooking rules for the special "BISCOTTO" version

- In the special version with BISCOTTO refractory surface the maximum temperature that can be set is **500°C**
- Turn on the oven at least two hours before starting work by setting the following parameters:
Minimum working temperature 400°C
Sky resistance 80%
Audience resistance 30%
Chimney closed "0".

5.13.d - Oven starting

- In case the oven has been set with a weekly starting programming, at the set time it starts with the value of the various parameters belonging to the programme selected in the weekly programming phase.
If weekly scheduling was not set, press button



The oven turns on with the last set program, if the program needs to be changed, select the desired program.

- When the oven turns on, the icons and flash, indicating that the oven is heating up and therefore the chimney remains closed and the extractor is stopped.

When the baking temperature is reached the two icons stop flashing and will start automatically with the settings pertaining to the selected program.



IMPORTANT

The start-up/positioning of the chimney and the extractor can be forced by moving to the icon and pressing the knob.

- Wait, until the oven reaches the temperature set for

baking the pizza.

5.14 - PIZZA BAKING

- Once the set temperature is reached, open the access door and insert the pizza to be baked.



ATTENTION



Inside the oven, temperature is very high, therefore suitable individual protection means shall be used to insert and remove the pizza; RISK OF BURNS.

- When the door is opened, the extractor, if set, starts at maximum speed, preventing steam from venting out of the chamber.
- During cooking, it is possible to change the parameters through the special keys, as correctly explained in the previous paragraph.
In the event some baking programme parameters have been changed (digital oven), if the oven is turned off, the changed parameters will NOT be stored.
- Once the pizza is baked, open the oven access door and remove the baked pizza.

5.14.a Suggestions for a right baking

A right chimney adjustment is important to correctly bake the pizza.

- If the chimney is entirely closed during cooking, during the pizza cooking, steam will come out from the door. What is more the ceiling resistance power will be consistently reduced because of the steam presence, and therefore the pizza will generally cook more on the lower part and less on the upper part.



IMPORTANT

It is advisable to utilize the chimney in the automatic mode set in the baking programme.

- If the chimney is directly connected with an aspirator, too much heat will be extracted from the oven and this will result a too dry pizza also being burnt in its lower side.

5.15 -ALARMS

Chimney malfunction (Fig. 15)

When this alarm is shown on the display, symbols (1) and (2) appear.

This alarm indicates a malfunction of the chimney movement.

Turn off the oven and contact the technical support to check the chimney motor, the limit switch and the mechanical gears.



Technical compartment overheating (Fig. 16)

When you insert this alarm on the display, the symbol (1) appears and alternating between the symbols (2) and (3).

This alarm indicates that the temperature within the technical compartment reached a high value, in this case the oven continues to operate; turn off the oven as soon as possible and contact the technical support to check proper operation of the technical compartment

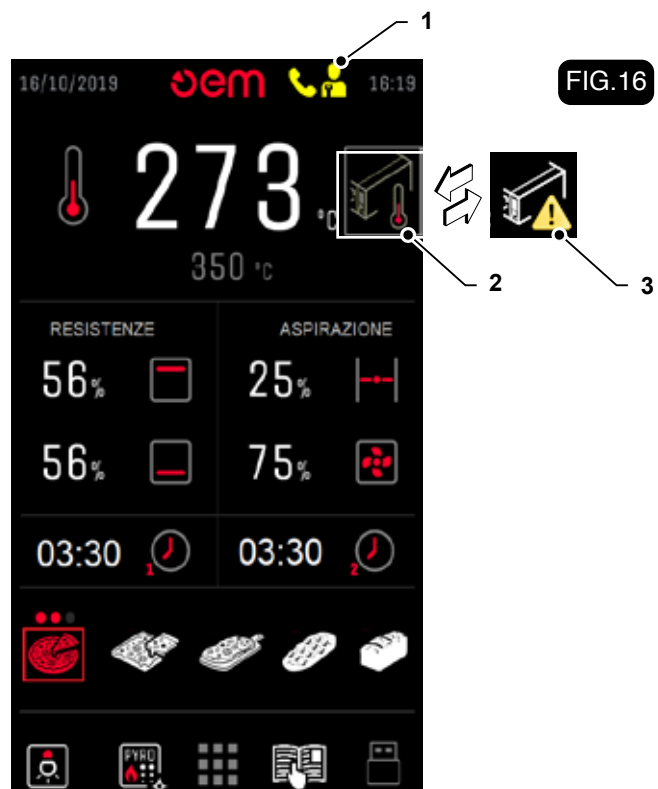

cooling fans.

Power board temperature probe open circuited or disconnected

When this alarm is activated, the “NTC” alarm appears on the display.

This alarm indicates that the power board probe is faulty or disconnected.

Call the technical support to replace the board



occurs again.

Chamber temperature probe open circuited or disconnected

When this alarm is activated, the “TC1” alarm appears on the display.

This indicates that the chamber temperature probe is open circuited or disconnected; the oven is turned off.

Call the technical support to check and/or replace the



Safety thermostat

When this alarm is activated, the “TS” alarm appears on the display.

Indicates that the temperature in the chamber has exceeded the maximum temperature; the oven heating system is turned off. Reset the safety thermostat as described in the relevant paragraph.

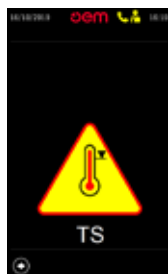

probe.

Chamber temperature probe short circuit

When this alarm is activated, the “TC1” alarm appears on the display.

This indicates that the chamber temperature probe is short circuited; the oven is turned off.

Call the technical support to replace the probe.



Chamber overheating

When this alarm is activated, the “TC1” alarm appears on the display. Indicates that the temperature in the chamber has exceeded the maximum temperature; the oven heating system is turned off.

Turn off the oven and wait for the chamber to cool down. Try again and call the technical support if the alarm

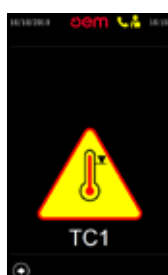

Technical compartment temperature probe open circuited or disconnected (only for American market)

When this alarm is activated, the “TC2” alarm appears on the display

This indicates that the technical compartment temperature probe is open circuited or disconnected; the oven is turned off.

Call the technical support to check and/or replace the

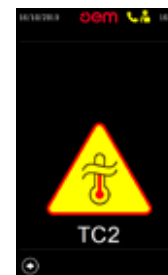

probe.

Technical compartment temperature probe short circuit

(only for American market)

When this alarm is activated, the “TC2” alarm appears on the display

This indicates that the technical compartment temperature probe is short circuited; the oven is turned off.



Call the technical support to replace the probe.

Main board heat sink overheating

When this alarm is activated, the “NTC” alarm appears on the display.

This alarm indicates that the temperature of the power board heat sink reached an excessive value.

Turn off the oven and check proper operation of the

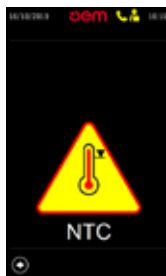

cooling fans of the technical compartment.

Power board heat sink temperature probe short circuit

When this alarm is activated, the “NTC” alarm appears on the display.

This indicates that the main board temperature probe is short circuited; the oven is turned off.

Call the technical support to replace the power board.

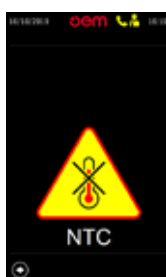

5.15.a Steamer alarms

Safety thermostat

When you insert this alarm on the display, next to the steamer symbol, the symbol (1) and (2) appears. Indicates that the temperature inside the steamer has exceeded the maximum temperature; the heating of the steamer is turned off.

Rearm the safety thermostat as indicated in its para-



graph.

Interrupted probe

When you insert this alarm on the display, next to the steamer symbol, the symbol (1) and (2) appears. It indicates that the temperature probe inside the steamer is interrupted or disconnected; the steamer is turned off. Call the technical support service for the control and/or

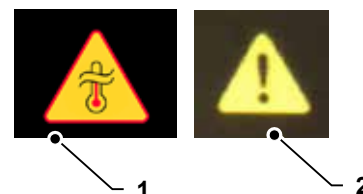

replacement of the probe.

Steamer in “Over-temperature” alarm

When you insert this alarm on the display, next to the steamer symbol, the symbol (1) and (2) appears. Indicates that the temperature inside the steamer has exceeded the maximum temperature; the heating of the steamer is turned off.

Try restarting the steamer again, if the alarm goes back, call the technical support service.

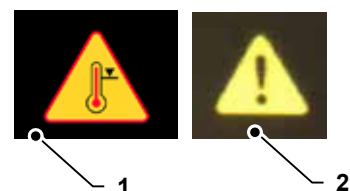

Probe in short-circuit

When you insert this alarm on the display, next to the steamer symbol, the symbol (1) and (2) appears. It indicates that the temperature probe inside the steamer is in short-circuit; the steamer is turned off.

Call the technical support service for the control and/or

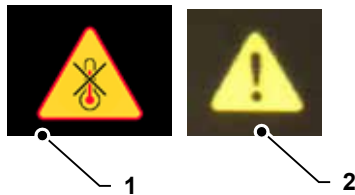

replacement of the probe.

5.16 - SWITCH-OFF (Fig. 17)

- At the end of each working day switch off the oven by  (1).

5.17 - MALFUNCTIONING, CAUSE AND CURE

- The oven does not start:

- Verify the electric connection.
- Make sure the cutout switch is on.
- Contact manufacturer's technical service.

- Oven malfunctioning:

Contact manufacturer's technical service.



For all other troubles, do not hesitate to contact manufacturer's technical service.

FIG. 17

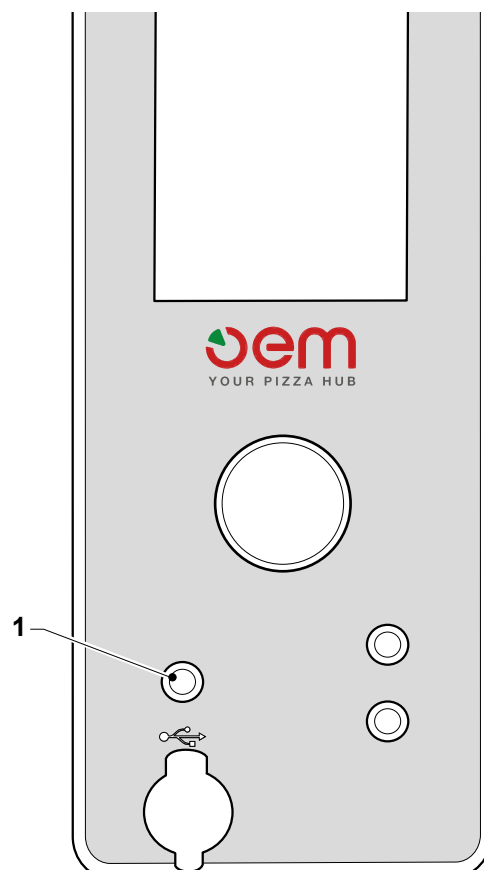

Chapter 6

6.1 - ROUTINE AND PLANNED MAINTENANCE

6.1.a- In general



All maintenance operations must be carried out with an off and cold oven, and with the line sectioner, positioned upstream of the oven, disengaged in the “OFF” ① position.

Maintenance operations have been subdivided into three categories:

- **ROUTINE MAINTENANCE:**
It includes all the maintenance works to be made on the machine everyday.
- **PLANNED MAINTENANCE:**
It includes all the maintenance works to be made according to a maintenance plan in order to ensure a correct working of the machine.
- **MAINTENANCE IN CASE OF NEED:**
Some operations to be carried out in case of need, for instance the replacement of broken or worn components.

6.1.b - Ordinary maintenance

6.1.b.a - Self-cleaning cycle (Fig. 1)

The oven is provided with automatic pyrolysis program.

By acting on the display and pressing the "🔥" icon (Pos. 11 - Fig. 3) it is possible to activate this function.

A screen will appear showing the chamber temperature (1), which must reach 400°C before the 20-minute countdown starts as shown in field (2). The oven will switch off automatically at the end of this

time.

If you want to exit this function, simply press on the appropriate exit icon (3).



IMPORTANT

Should you switch off the oven before the end of the cleaning cycle, the cleaning program will restart automatically once you turn again the oven on.

FIG. 1



- The following day to the cleaning cycle, it is possible to brush the refractory.

6.1.b.b - Outer cleaning



ATTENTION

At the end of each working cycle, carefully clean the oven.

To clean the oven, NEITHER metallic objects such as steel wool, brushes, scrapers NOR corrosive products shall be used.

Do NOT utilize water jets to clean the oven sides.

- To clean the outer side of the oven, you shall use a wet cloth as well as a detergent suitable for the surface to be treated.

6.1.b.c - Refractory surface cleaning (Fig 2)

- Make sure the oven is totally cool, open the door and clean the refractory surface (1) by the special scrubber.

6.1.c - Scheduled service interventions

- According to the hours of use and the operating load, it is possible to schedule service at least once a year.



ATTENTION

The interventions described below must be carried out by specialized and expressly authorized technical personnel.

6.1.d - Service intervention according to the specific requirements

6.1.d.a - Lamp replacement (Fig. 3)

(Version with Frame)

- Undo the two knobs (1) and remove the frame (2) with the relevant glass (3).
- Replace the lamp (4).



ATTENTION

It is an halogen lamp do NOT touch with

FIG. 2

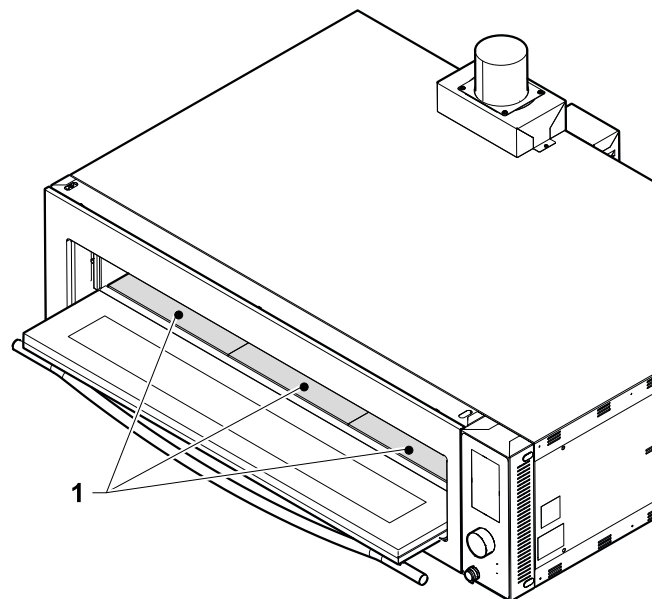
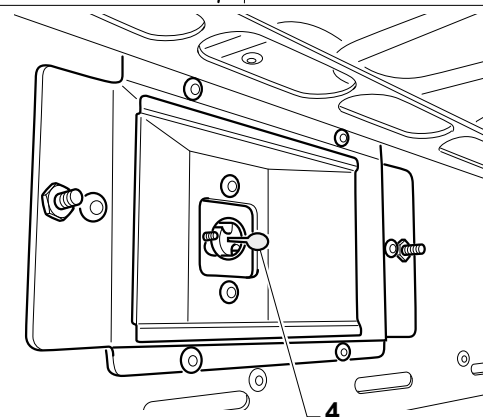
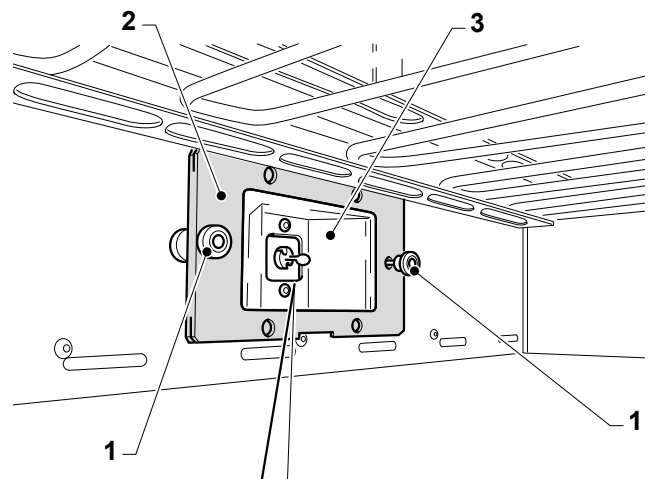

FIG. 3



your fingers: : DANGER OF BURNS.

(Version with removable glass)

- Remove the glass (1) using your fingers or a flat tool.
- Replace bulb (2).
- Reassemble the glass (1) pushing it towards the frame (3).



ATTENTION



It is an halogen lamp do NOT touch with your fingers: DANGER OF BURNS.

FIG. 4

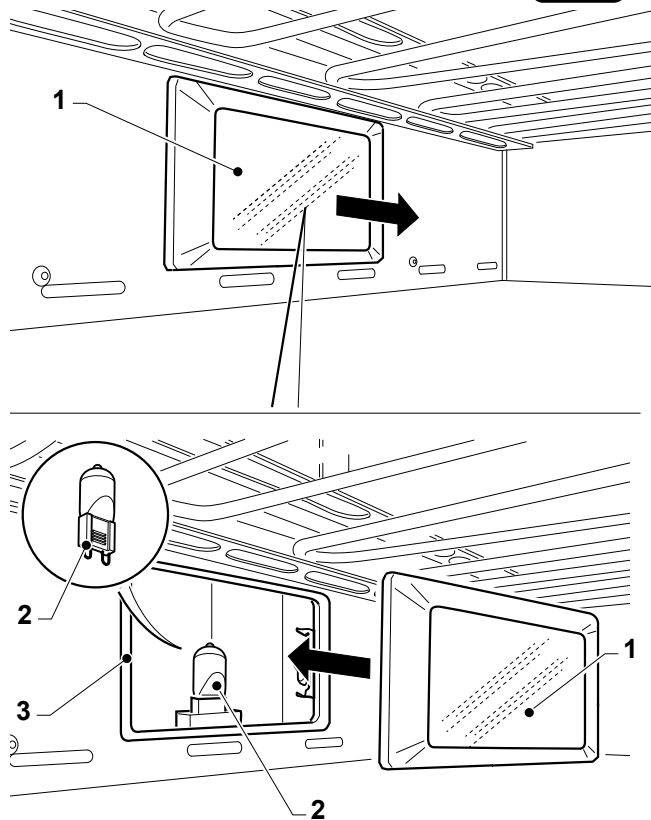

FIG. 5

6.1.d.b - How to clean the cooling fan of the switch-board (Fig. 4)

In case the oven displays the trouble report “TECHNICAL COMPARTMENT/POWER BOARD OVERHEATING”, you shall provide cleaning the cooling fan of the switchboard as follows:

- remove the right-hand side (1) and provide removing the dirt settled on the fan, by means of jets of compressed air.



IMPORTANT

In the event the oven shows again the aforementioned trouble report, please

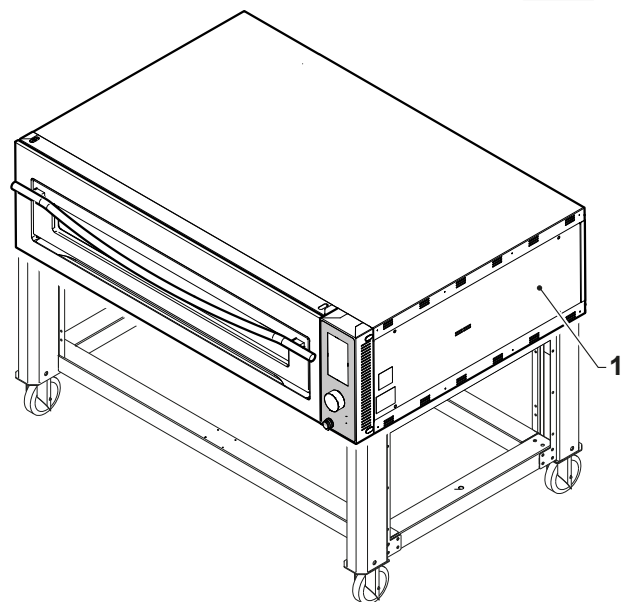

contact our technical service personnel.

6.2 - RESETTING THE SAFETY THERMOSTAT



Make sure that the power to the electric panel has been cut.

Operate as follows to reset the safety thermostat:

- Unscrew the two screws (1).

- Open the door and unscrew the screw (2).

- Pull out the electrical component panel (3)
- Press the red button (4) to reset the safety thermostat located within the technical compartment.
- Refit everything operating in reverse order from removal.



If the thermostat is re-inserted several times it indicates that there is some problem in

FIG. 6

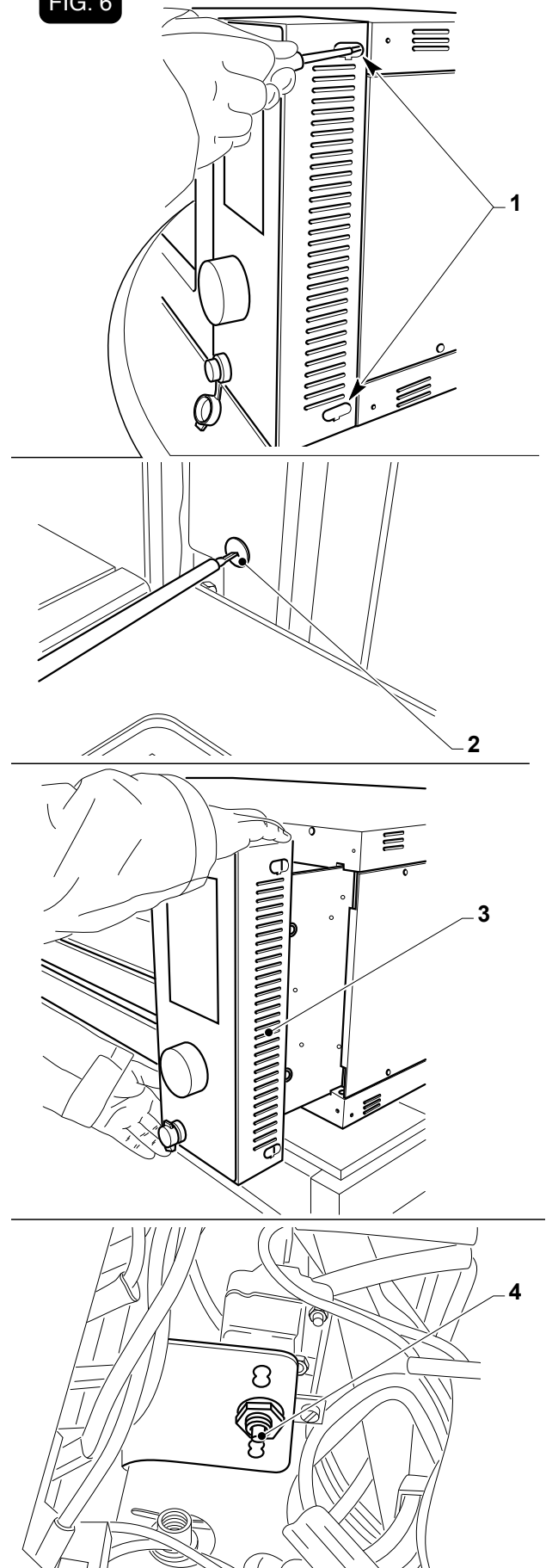

the oven.

Call technical support.

6.3 - REACTIVATION OF THE STEAMER SAFETY THERMOSTAT

To reactivate the safety thermostat, press the red button (1) that comes out of the panel (2).



ATTENTION



If the thermostat activates several times it indicates that there is some problem in the steamer.

Call the Technical Support.

FIG. 7

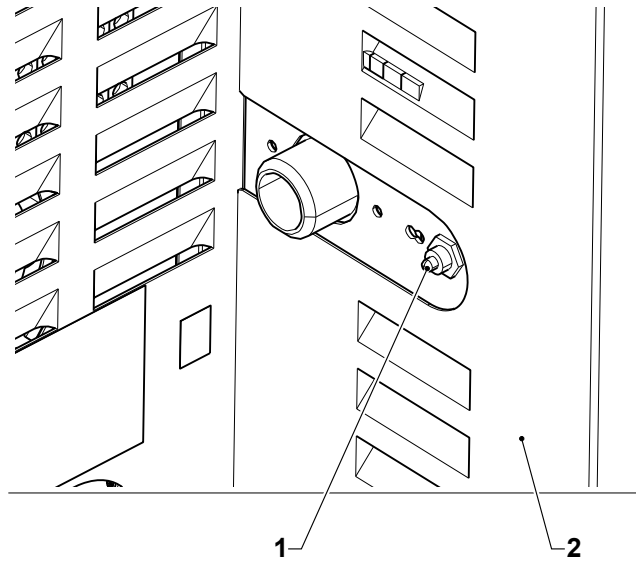

Chapter 7

7.1 - MACHINE DISASSEMBLING

In the event the machine shall be disassembled, to install it again you shall proceed in the reverse order in comparison with the instructions reported in “Installation” chapter.



Before disassembling the machine or demounting some machine components, disconnect the power supply.

The machine assembling shall only be carried out by skilled and authorized personnel.



In case it is necessary to disassemble the machine or demount some machine components in a different way in comparison with the written instructions, Company OEM or its Agent shall be contacted - see addresses on the third page of this publication.

7.2 - DEMOLISHING THE MACHINE

Proceed as described below if the machine is to be scrapped for any reason:

- Disconnect the machine by complying with the instructions given in chapter “Installation” of this publication, working in reverse order.
- Disassemble all possible machine components (casings, lamps, guards, handles, chains, motors, etc.) and divide them according to their different nature (eg.: pipes, rubber components, lubricants, solvents, coating products, aluminium, ferrous materials, copper, glass, etc.).
- Before scrapping the machine, notify the competent authorities by written communication in compliance with the laws in force in each individual country.
- After having received authorization from the above mentioned authorities, dispose of the machine components as prescribed by the current provisions in

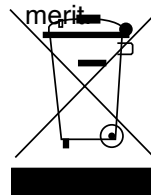

To protect the environment, please proceed in compliance with the local laws in force.

When the machine can no longer be used or repaired, please proceed with recycle and disposal.

Electrical equipment cannot be disposed of as ordinary urban waste: it must be disposed of according to the special EU directive for the recycling of electric and electronic equipment (leg. decree no. 49 dated 14/03/2014 implementing the directive 2012/19/EU RAEE and leg. decree no. 27 dated 4/03/2014 implementing directive 2011/65/EU ROHS).

Electrical equipment is marked with a pictogram of a garbage can inside a barred circle. This symbol means that the equipment was sold on the market after August 13, 2005, and must be disposed of accordingly.

Due to the substances and materials it contains, inappropriate or illegal disposal of this equipment, or improper use of the same, can be harmful to humans and the environment. Improper disposal of electric equipment that fails to respect the laws in force will be subject to administrative fines and penal sanctions.



Consult the next paragraph when disposing of harmful materials (lubricants, solvents, coating products, etc.).

7.3 - DISPOSING OF HARMFUL SUBSTANCES

Consult the provisions established by the Standards in force in each individual country before disposing of such substances.



Any improper use by the Customer before, during or after scrapping and disposing of the parts of the machine, in respect of the construction and application of the applicable regulations, shall be the customer’s responsibility.

“SUPER TOP” OVEN DIAGRAM - 208/240 Volt 3Ph + PE

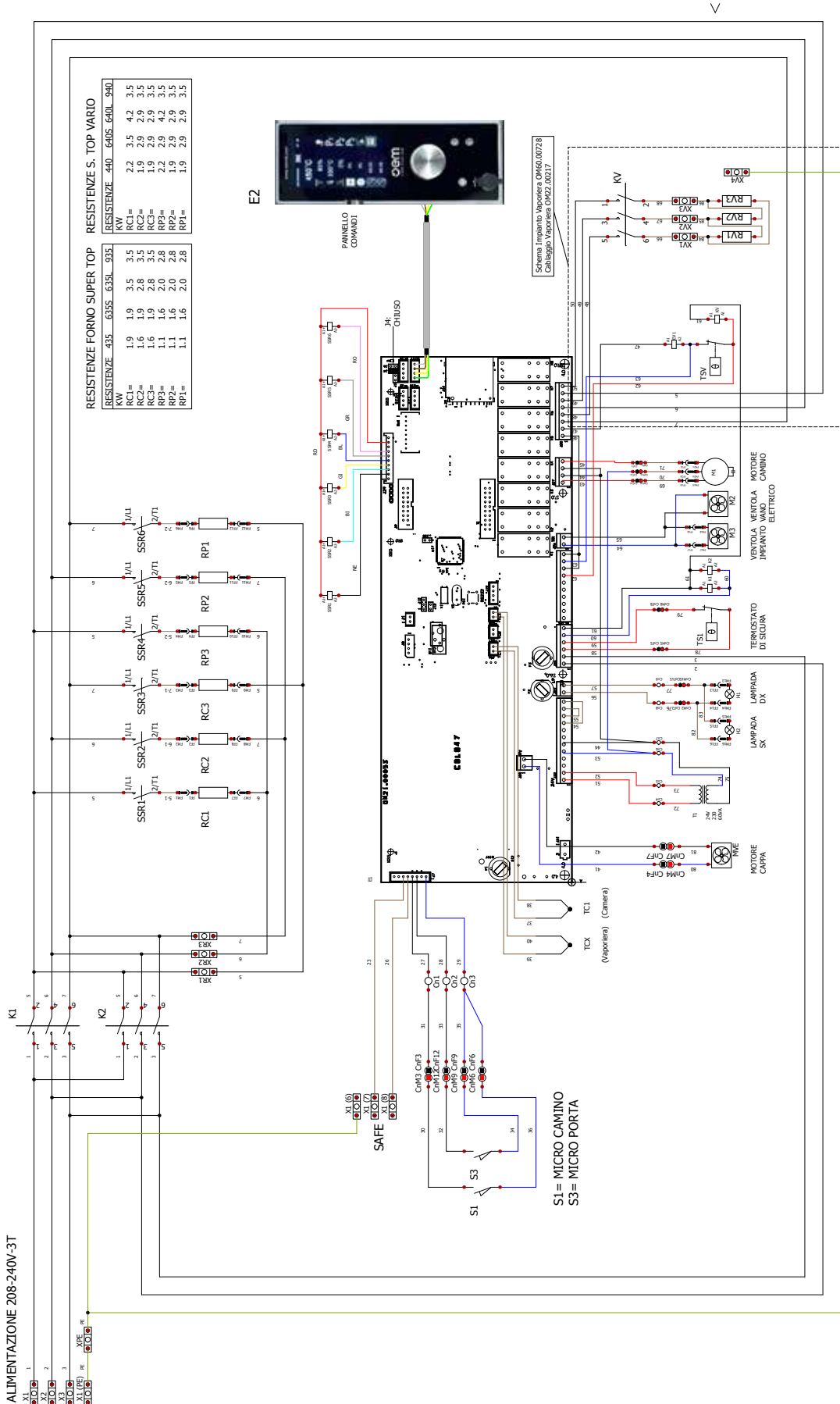

“SUPER TOP” OVEN DIAGRAM KEY - 208/240 Volt 3Ph + PE

E1	Power board
E2	7" Touch Displa
EV1	Steamer solenoid valve
F2	Lamp fuse
F3	Board power fuse
H1	Cooking chamber lamps
H2	Cooking chamber lamps
K1	General contactor
KV	Steamer contactor
M1	Chimney motor
M2	Cooling Fans
M3	Cooling Fans
MV3	Suction motor Cooking chamber
RC1	Upper input resistance
RC2	Central upper resistance
RC3	Superior bottom resistance
RP1	Lower input resistance
RP2	Central lower resistance
RP3	Lower bottom resistance
RV1	Steamer resistors
RV2	Steamer resistors
RV3	Steamer resistors
S1	Chimney microswitch
S3	Door microswitch
T1	Board Power Transformer
TC1	Chamber temperature probe
TCX	Steam temperature probe
TS1	Safety thermostat
TSV	Steamer safety thermostat
X1 (1)	Clamp
X1 (2)	Clamp
X1 (3)	Clamp
X1 (6)	Clamp
X1 (7)	Clamp
X1 (8)	Clamp
X1 (N)	Clamp
X1 (PE)	Clamp
X3	Clamp
X4	Clamp
XPE	Electrical earth terminal
XV1	Steamer clamp
XV2	Steamer clamp
XV3	Steamer clamp
XV4	Steamer clamp
XV5	Steamer clamp

“SUPER TOP” OVEN DIAGRAM - 380/416 Volt 3Ph + N + PE

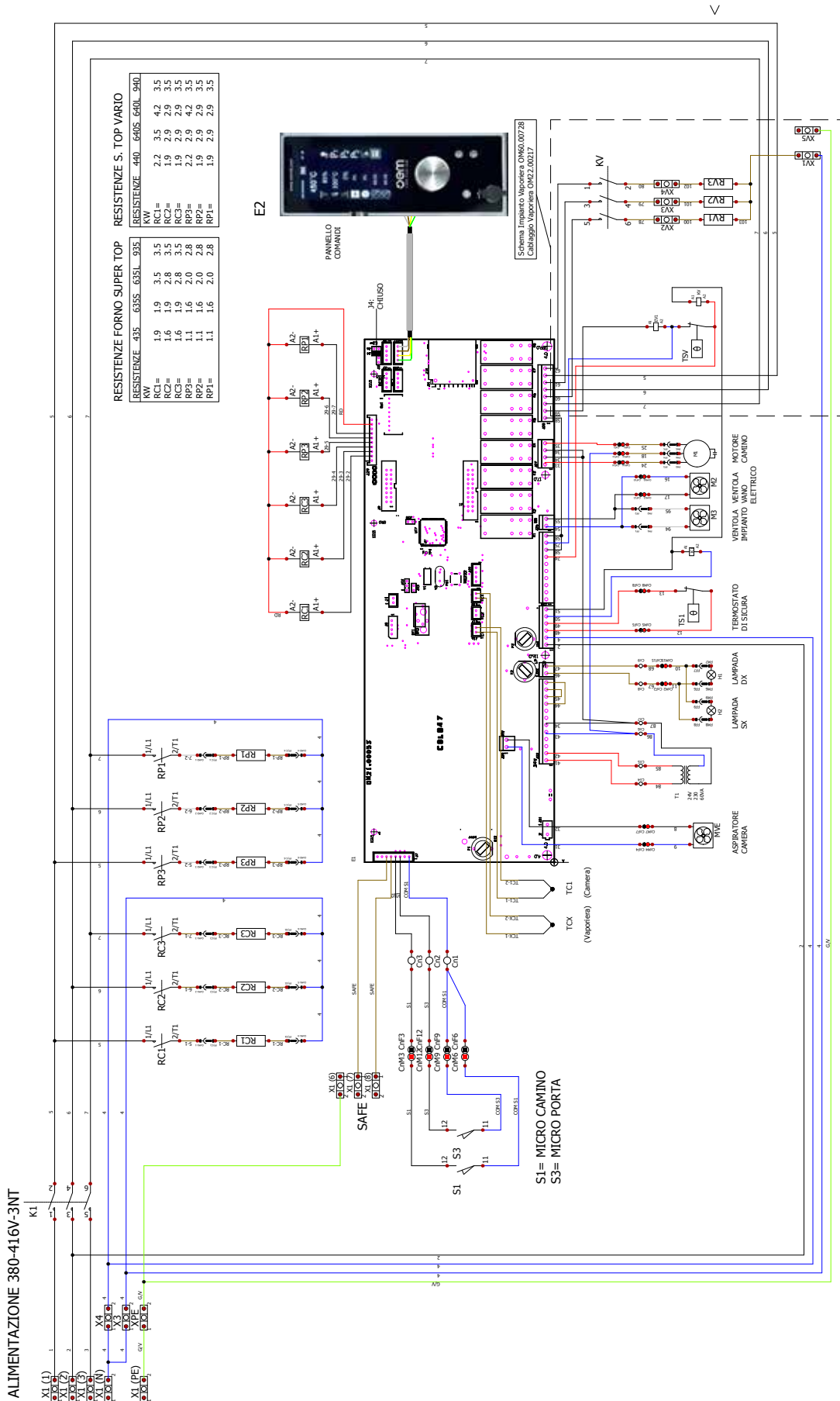

“SUPER TOP” OVEN DIAGRAM KEY - 380/416 Volt 3Ph + N + PE

E1	Power board
E2	7" Touch Displa
EV1	Steamer solenoid valve
F2	Lamp fuse
F3	Board power fuse
H1	Cooking chamber lamps
H2	Cooking chamber lamps
K1	General contactor
KV	Steamer contactor
M1	Chimney motor
M2	Cooling Fans
M3	Cooling Fans
MV3	Suction motor Cooking chamber
RC1	Upper input resistance
RC2	Central upper resistance
RC3	Superior bottom resistance
RP1	Lower input resistance
RP2	Central lower resistance
RP3	Lower bottom resistance
RV1	Steamer resistors
RV2	Steamer resistors
RV3	Steamer resistors
S1	Chimney microswitch
S3	Door microswitch
T1	Board Power Transformer
TC1	Chamber temperature probe
TCX	Steam temperature probe
TS1	Safety thermostat
TSV	Steamer safety thermostat
X1 (1)	Clamp
X1 (2)	Clamp
X1 (3)	Clamp
X1 (6)	Clamp
X1 (7)	Clamp
X1 (8)	Clamp
X1 (N)	Clamp
X1 (PE)	Clamp
X3	Clamp
X4	Clamp
XPE	Electrical earth terminal
XV1	Steamer clamp
XV2	Steamer clamp
XV3	Steamer clamp
XV4	Steamer clamp
XV5	Steamer clamp

INTENTIONALLY WHITE PAGE

INTENTIONALLY WHITE PAGE

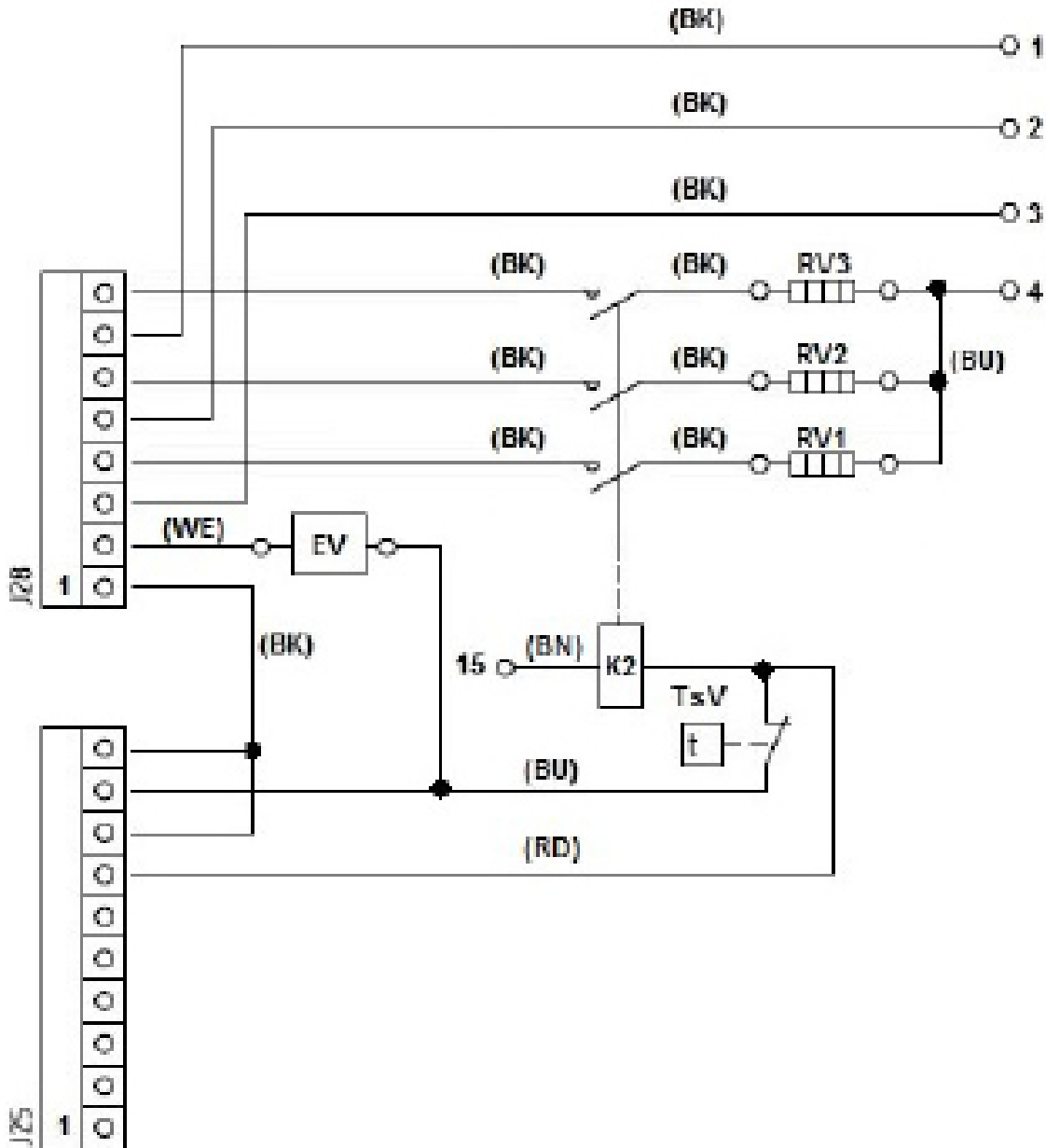

**“VARIO” OVEN STEAM COOKER DIAGRAM
OM23.00500 OVEN DIAGRAM KEY**

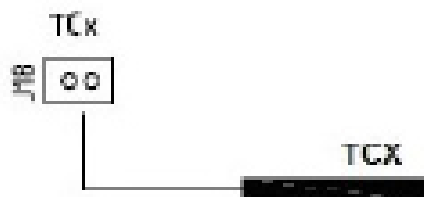

- TCX** TEMPERATURE SENSOR
- EV** DELIVERY SOLENOID VALVE
- K2** SAFETY CONTACTOR
- RV1** STEAM COOKER HEATING ELEMENT 1
- RV2** STEAM COOKER HEATING ELEMENT 2
- RV3** STEAM COOKER HEATING ELEMENT 3
- TSV** STEAM COOKER SAFETY THERMOSTAT



OEM ALI Group S.r.l. a Socio Unico

Viale Lombardia, 33

Tel.: +39 0376 - 910511

Fax: +39 0376 - 910545

info@oemali.com

www.oemali.com